

DESIGN GUIDE MD #8

WALL DESIGNS AND DETAILS FOR WASTE STORAGE

(Index of Standard Detail Drawings by NRCS)

*Natural Resources
Conservation Service
Maryland*

Revised - February, 2017

TABLE OF CONTENTS

SECTION		PAGES
I	General Information	1
II	Concrete Wall Construction Specifications	3
III	Index of Standard Detail Drawings (Prequalified Designs)	5
IV	Data Sheet Summaries	7
V	Appendix (Standard Detail Drawings)	41

SECTION I

General

Standard engineering designs are to be used as part of a site-specific design; the site-specific design must be reviewed and approved by someone with the appropriate engineering approval authority. Any design changes in these requirements must be approved by an NRCS engineer, prior to construction.

Geotechnical Investigations

Criteria for allowable soil bearing capacity based on foundation description is contained in the Waste Storage Facility conservation practice standard (code 313) Table 2- Presumptive Allowable Bearing Stress Values. Site soil investigations are to include a soil foundation description that corresponds to Table 2. The actual soil bearing (allowable stress) capacity for the site must meet or exceed the soil bearing capacity required by the design. When the actual soil bearing capacity (based on foundation description) is less than that required by the design the design cannot be used unless site specific testing, for soil bearing capacity is performed and the site soil bearing capacity is found to meet or exceed the required soil bearing capacity for the planned design. Testing is to be performed by a qualified geotechnical engineering representative. A copy of the test report must be kept on file with the engineering plans. The testing must be complete prior to start of construction.

Curing Concrete

Proper curing of concrete is required. Curing must be accomplished by protecting the concrete from drying during the curing period by leaving forms in place, spraying or sprinkling the concrete with water, covering with wet burlap or plastic sheeting, or by use of a curing compound. The protection must be applied immediately after the initial set of the concrete. A minimum curing period of 3 days is required when atmospheric temperatures are at or above 55° F or 7 days when the atmospheric temperature is below 55° F. Concrete must be kept from freezing during the curing period.

Wall Joints

Provide expansion joints in walls at spacing no greater than 60 feet. Do not locate expansion joints in wall corners or at locations of column anchors. Construct in accordance with the wall expansion joint detail.

Column Anchors

Curbs and L wall are not suitable support for column anchors that will support a roof load. Specific wall designs have been included for 2' concrete walls that will support roof loads. The maximum post depth for these walls is 8 inches. Posts widths may vary with suitable column anchors.

Floor Steel Requirements

Provide floor steel in accordance with the requirements below. For large floor areas expansion joints may be added to reduce steel requirements.

CONCRETE STORAGE FACILITIES		
<i>MAXIMUM FLOOR DIMENSION</i>	<i>REQUIRED STEEL FOR 5" THICK FLOOR W/ GRAVEL SUBGRADE</i>	
	<i>A_s</i>	<i>EXAMPLE</i>
$\leq 60'$	0.058	6x6-#6 gage, or 6x6-W2.9xW2.9, or #3 bar @ 18 inch
$>60' \leq 100'$	0.126	4x4-#4 gage, 4x4-W4xW4, or #4 @ 18"
$>100' \leq 160'$	0.190	#4 @ 12"
$>160' \leq 200'$	0.230	#4 @ 10" or #5 bar @ 16"

SECTION II

CONCRETE CONSTRUCTION SPECIFICATIONS

Revised 2/17

1. All materials and construction shall be in accordance with applicable NRCS Practice Standards and ACI-318.
2. Any changes in the plans or specifications must be approved by the design approver prior to being made. Changes are to be reviewed by the landowner for concurrence.
3. Concrete shall have Type IA or IIA cement, 28-day compressive strength of 4,000 psi, 5% air entrainment and a slump of 3 to 5 inches. Air entrainment admixtures shall conform to ASTM C260.
4. Reinforcing steel shall conform to ASTM A615, Grade 60 steel. All reinforcing material shall be free of dirt, loose rust, scale, oil, paint or other coatings. The steel shall be accurately placed into position, as shown on the plans, and securely restrained and blocked into position prior to placement of concrete. Insertion of steel into fresh concrete is not permitted. Reinforcement steel shall have a minimum of 2 inches of concrete cover against all forms and 3 inches against soil, unless otherwise shown on the plans. Ring steel shall have a minimum overlap of 24 inches. All other reinforcement steel splices shall overlap a minimum of 18 inches. Welded wire mesh shall conform to ASTM A1064 and overlap a minimum of 6 inches. The welding of reinforcing steel is not permitted.
5. Waterstop will be used as shown on the plans and at all cold and construction joints. The type of waterstop will be approved by the field technician prior to use.
6. Plasticizing or plasticizing and retarding admixtures may be used and shall conform to ASTM C1017 or ASTM C494 Types F or G.
7. Concrete forms shall have sufficient strength and rigidity to hold the concrete to withstand the necessary pressure, tamping and vibration without deflection from the prescribed lines. They shall be mortar-tight and constructed so that they can be removed without hammering or prying against the concrete. The inside of the forms shall be oiled with a non-staining mineral oil or thoroughly wet before concrete is placed. Forms may be removed 24 hours after the placement of concrete.
8. Metal ties or anchorages shall be full dimension. Nominal size wall ties are not permitted. Wall tie ends must be broken off and patched with a concrete epoxy or polymer cement. Patching is required on both the inside and outside of concrete structures.
9. Concrete shall be delivered to the site and discharged completely into the forms within 90 minutes after the truck leaves the plant. This time shall be reduced to 45 minutes when the atmospheric temperature is over 90⁰ F. The concrete shall be maintained at a temperature below 90⁰ F during mixing, conveying and placement. Set retarding admixtures may be used to increase mixing time. Water reducing and/or retarding admixtures shall conform to ASTM C494 Types A, B, D, F or G.
10. All concrete for walls shall be consolidated with internal type mechanical vibrators or by rodding. Concrete shall be placed in horizontal lifts not greater than 2 feet. Concrete shall not have a vertical drop greater than 5 feet. An elephant trunk, chute, or similar means shall be used when applicable to minimize the vertical drop. Vibration shall be supplemented by spading and hand tamping as necessary to insure smooth and dense concrete along form surfaces, in corners, and around embedded items.

11. Concrete shall not be placed when the daily minimum atmospheric temperature is less than 40° F unless facilities are provided to prevent the concrete from freezing. The concrete shall be protected from freezing for a minimum of 7 days or the concrete shall be kept at a temperature of 55° F for a minimum of 3 days. Accelerating or water-reducing and accelerating admixtures shall be noncorrosive and conform to the requirements of ASTM C494, Types C and E. Cold weather concreting procedures shall conform to ACI-306.
12. Concrete shall be kept continuously moist for the curing period after the placement of the concrete. Moisture may be applied by spraying or sprinkling as necessary to prevent the concrete from drying. Concrete shall not be exposed to freezing during the curing period. Curing compounds may be used in lieu of the application of moisture. Curing compounds shall conform to ASTM C309, type 2.
13. Defective concrete, honeycombed areas, voids left by the removal of tie rods, ridges on all concrete surfaces permanently exposed to view or exposed to water, shall be repaired immediately after the removal of forms. All voids shall be reamed and completely filled with quickset, non-shrink hydraulic cement, concrete epoxy or polymer cement. Voids left by wall ties shall be patched with a concrete epoxy or polymer modified cement.
14. Concrete top surfaces shall be screeded, troweled and broom finished unless otherwise approved.
15. Walls may be backfilled 7 days after the placement of concrete, unless otherwise approved.
16. Fill material under concrete shall be accomplished by placing maximum 8-inch lifts (before compaction). The lifts shall be compacted by the traversing of the entire surface by not less than one track of the equipment or by a minimum of four complete passes with a sheepsfoot, vibratory, or rubber tire roller.

Compaction around structures (i.e. around pipes, adjacent to walls, etc.) shall be accomplished by placing fill in maximum 4-inch lifts and compacting by means of hand tampers or other manually directed compaction equipment.

The technician shall determine if the moisture content is suitable for fill placement. The contractor shall make adjustments as directed by the technician. The method of compaction shall be approved prior to placement of fill material.
17. The backfill behind walls shall conform to the grades shown on the plans. When placing uncompacted fill provide an additional foot of fill to allow for settlement.
18. Subsurface drainage must be provided as shown on the plans. Drain tubing must meet the requirements of ASTM F405 Heavy Duty.

SECTION III

Index of Standard Detail Drawings by NRCS, Maryland

NUMBER	DESCRIPTION	SURCHARGE	ISSUE DATE
CF-5	Concrete Floor	None	2/04
CW-C8	Corner Detail for 8 inch thick wall	None	2/17
CW-C10	Corner Detail for 10 inch thick wall	None	2/17
CW-C12	Corner Detail for 12 inch thick wall	None	3/04
CW-C14	Corner Detail for 14 inch thick wall	None	3/04
CC-1.1.8	8" Concrete Curb	None	3/04
CC-1.1.0L	10" Concrete Curb	None	3/04
CC-1.1.12	12" Concrete Curb	None	3/04
CC-1.1.18	18" Concrete Curb	None	3/14
RCC-6.0	Concrete Rolled Curb	N/A	2/15
RCC-6.1	Concrete Rolled Curb - Half	N/A	2/15
C.Joint	Controlled Concrete Joint Detail	N/A	2/15
CW-2.2.1W	2' Concrete T Wall with Column Anchor	100 PSF	2/17
CW-2.2.2W	2' Concrete T Wall with Column Anchor and Feed Pad	100 PSF	2/17
CW-2.2.0L	2' Concrete L Wall with backfill limits of 0 to 2 feet	100 PSF	2/17
CW-3.3.1L	3' Concrete L Wall with backfill limits of 1 to 3 feet	100 PSF	2/17
CW-3.3.0L	3' Concrete L Wall with backfill limits of 0 to 3 feet	100 PSF	2/17
CW-4.4.1	4' Concrete T Wall with backfill limits of 1.5 to 4 feet	100 PSF	2/17
CW-4.4.0	4' Concrete T Wall with backfill limits of 0 to 4 feet	100 PSF	2/17
CW-4.4.1L	4' Concrete L Wall with backfill limits of 1 to 4 feet	100 PSF	2/17
CW-4.4.0L	4' Concrete L Wall with backfill limits of 0 to 4 feet	100 PSF	2/17
CW-4.4.4R	4' Concrete T Wall Restrained at the top	250 PSF	2/17
CW-5.5.1	5' Concrete T Wall with backfill limits of 1 to 5 feet	100 PSF	2/17

NUMBER	DESCRIPTION	SURCHARGE	ISSUE DATE
CW-5.5.0	5' Concrete T Wall with backfill limits of 0 to 5 feet	100 PSF	2/17
CW-5.5.1L	5' Concrete L Wall with backfill limits of 1 to 5 feet	100 PSF	2/17
CW-5.5.0L	5' Concrete L Wall with backfill limits of 0 to 5 feet	100 PSF	2/17
CW-6.6.1	6' Concrete T Wall with backfill limits of 1.5 to 6 feet	100 PSF	2/17
CW-6.6.0	6' Concrete T Wall with backfill limits of 0 to 6 feet	100 PSF	2/17
CW-6.6.1L	6' Concrete L Wall with backfill limits of 1.5 to 6 feet	100 PSF	2/17
CW-6.6.0L	6' Concrete L Wall with backfill limits of 0 to 6 feet	100 PSF	2/17
CW-6.6.6R	6' Concrete T Wall Restrained at the top	250 PSF	2/17
CW-7.7.2	7' Concrete T Wall with backfill limits of 2 to 7 feet	100 PSF	2/17
CW-7.7.0	7' Concrete T Wall with backfill limits of 0 to 7 feet	100 PSF	2/17
CW-8.8.2	8' Concrete T Wall with backfill limits of 2 to 8 feet	100 PSF	2/17
CW-8.8.0	8' Concrete T Wall with backfill limits of 0 to 8 feet	100 PSF	2/17
CW-8.8.8R	8' Concrete T Wall Restrained at the top	250 PSF	2/17
CW-10.10.3	10' Concrete T Wall with backfill limits of 3 to 10 feet	100 PSF	2/17
CW-10.10.0	10' Concrete T Wall with backfill limits of 0 to 10 feet	100 PSF	2/17
CW-10.10.10R	10' Concrete T Wall Restrained at the top	250 PSF	3/04
CW-12.12.4	12' Concrete T wall with backfill limits of 4 to 12 feet	100 PSF	3/04
CW-12.12.0	12' Concrete T wall with backfill limits of 0 to 12 feet	100 PSF	3/04
CW-12.12.12R	12' Concrete T Wall Restrained at the top	250 PSF	3/04

Key

Wall Type – Wall Height.Maximum Backfill.Minimum Backfill.(L, R or T)

CW = Concrete Wall

CF = Concrete Floor

CC = Concrete Curb

RCC = Rolled Concrete Curb

L = L Wall

T = T Wall

R = Restrained Wall (at top)

SECTION IV

Data Sheets for Standard Detail Drawings (Prequalified Designs) Receiving Concurrence for Use in Maryland

8 INCH CONCRETE CURB

Designer: NRCS Maryland.

Drawings: CC-1.1.8

Issue Date: March, 2004

Applications: Maryland Conservation Practice Standard for Waste Storage Facility, code 313.

Assumptions: Grade 60 steel reinforcement.

4,000 psi concrete.

Footing is above high water table, or drainage is provided.

Minimum 4-inch cast-in-place concrete floor at base of wall.

Minimum soil bearing capacity of 2000 psf

Maximum Backfill 8 Inches

Minimum Backfill Level with top of floor

Manure with an Equivalent Fluid Pressure EFP of 65 lb/ft²/ft of depth.

Backfill Material Backfill material consists of a low to medium-plasticity silts and clays with little sand and/or gravel (50% or more fines). This material has an Equivalent Fluid Pressure EFP of 65 lb/ft²/ft of depth.

Materials: Concrete - 0.066 yd³/ft

Reinforcement - #4 Bar 4.8 lf/ft (Includes vertical overlaps as shown on drawings and horizontal overlap at 20 foot intervals)

10 INCH CONCRETE CURB

Designer: NRCS Maryland.

Drawings: CC-1.1.0L

Issue Date: March, 2004

Applications: Maryland Conservation Practice Standard for Waste Storage Facility, code 313.

Assumptions: Grade 60 steel reinforcement.

4,000 psi concrete.

Footing is above high water table, or drainage is provided.

Minimum 4-inch cast-in-place concrete floor at base of wall.

Minimum soil bearing capacity of 2000 psf

Maximum Backfill 10 Inches

Minimum Backfill Level with top of floor

Manure with an Equivalent Fluid Pressure EFP of 65 lb/ft²/ft of depth.

Backfill Material Backfill material consists of a low to medium-plasticity silts and clays with little sand and/or gravel (50% or more fines). This material has an Equivalent Fluid Pressure EFP of 65 lb/ft²/ft of depth.

Materials: Concrete - 0.067 yd³/ft

Reinforcement - #4 Bar 5 lf/ft

(Includes vertical overlaps as shown on drawings and horizontal overlap at 20 foot intervals)

12 INCH CONCRETE CURB

Designer: NRCS Maryland.

Drawings: CC-1.1.12

Issue Date: March, 2004

Applications: Maryland Conservation Practice Standard for Waste Storage Facility, code 313.

Assumptions: Grade 60 steel reinforcement.

4,000 psi concrete.

Footing is above high water table, or drainage is provided.

Minimum 4-inch cast-in-place concrete floor at base of wall.

Minimum soil bearing capacity of 2000 psf

Maximum Backfill 12 Inches

Minimum Backfill Level with top of floor

Manure with an Equivalent Fluid Pressure EFP of 65 lb/ft²/ft of depth.

Backfill Material Backfill material consists of a low to medium-plasticity silts and clays with little sand and/or gravel (50% or more fines). This material has an Equivalent Fluid Pressure EFP of 65 lb/ft²/ft of depth.

Materials: Concrete - 0.068 yd³/ft

Reinforcement - #4 Bar 5.4 lf/ft (Includes vertical overlaps as shown on drawings and horizontal overlap at 20 foot intervals)

18 INCH CONCRETE CURB

Designer: NRCS Maryland.

Drawings: CC-1.1.18

Issue Date: March, 2004

Applications: Maryland Conservation Practice Standard for Waste Storage Facility, code 313.

Assumptions: Grade 60 steel reinforcement.

4,000 psi concrete.

Footing is above high water table, or drainage is provided.

Minimum 4-inch cast-in-place concrete floor at base of wall.

Minimum soil bearing capacity of 2000 psf

Maximum Backfill 18 Inches

Minimum Backfill Level with top of floor

Manure with an Equivalent Fluid Pressure EFP of 65 lb/ft²/ft of depth.

Backfill Material Backfill material consists of a low to medium-plasticity silts and clays with little sand and/or gravel (50% or more fines). This material has an Equivalent Fluid Pressure EFP of 65 lb/ft²/ft of depth.

Materials: Concrete - 0.086 yd³/ft

Reinforcement - #4 Bar 6.4 lf/ft (Includes vertical overlaps as shown on drawings and horizontal overlap at 20 foot intervals)

2 FOOT CONCRETE COLUMN ANCHOR WALL

Designer: NRCS Maryland.

Drawings: CW-2.2.1W

Issue Date: February, 2017

Applications: Maryland Conservation Practice Standard for Waste Storage Facility, code 313.

Assumptions: Grade 60 steel reinforcement.

4,000 psi concrete.

Footing is above high water table, or drainage is provided.

Minimum 4-inch cast-in-place concrete floor at base of wall.

Minimum soil bearing capacity of 2000 psf

Maximum Backfill 2' with maximum 100 psf surcharge on wall.

Minimum Backfill 1' over top of Footing.

Manure with an Equivalent Fluid Pressure EFP of 65 lb/ft²/ft of depth.

Backfill Material Backfill material consists of a low to medium-plasticity silts and clays with little sand and/or gravel (50% or more fines). This material has an Equivalent Fluid Pressure EFP of 65 lb/ft²/ft of depth.

Equipment Access Areas

This wall is designed with a 100 psf surcharge on the wall. This is equivalent to the loading for livestock or a small farm tractor (6000 lb GVW).

Materials: Concrete - 0.140 yd³/ft

Reinforcement - #4 Bar 7 lf/ft

#5 Bar 6 lf/ft

(Includes vertical overlaps as shown on drawings and horizontal overlap at 20 foot intervals)

2 FOOT CONCRETE L-WALL

Designer: NRCS Maryland.

Drawings: CW-2.2.0L

Issue Date: March, 2004

Applications: Maryland Conservation Practice Standard for Waste Storage Facility, code 313.

Assumptions: Grade 60 steel reinforcement.

4,000 psi concrete.

Footing is above high water table, or drainage is provided.

Minimum 4-inch cast-in-place concrete floor at base of wall.

Minimum soil bearing capacity of 2000 psf

Maximum Backfill 2' with maximum 100 psf surcharge on wall.

Minimum Backfill Level with top of floor

Manure with an Equivalent Fluid Pressure EFP of 65 lb/ft²/ft of depth.

Backfill Material Backfill material consists of a low to medium-plasticity silts and clays with little sand and/or gravel (50% or more fines). This material has an Equivalent Fluid Pressure EFP of 65 lb/ft²/ft of depth.

Equipment Access Areas

This wall is designed with a 100 psf surcharge on the wall. This is equivalent to the loading for livestock or a small farm tractor (6000 lb GVW).

Bridge Slab

Where equipment larger than that shown above will be present, a different wall design or a bridge slab access pad extending a minimum of 4 feet from the back of the wall must be used.

Materials: Concrete - 0.140 yd³/ft

Reinforcement - #4 Bar 7 lf/ft

#5 Bar 6 lf/ft

(Includes vertical overlaps as shown on drawings and horizontal overlap at 20 foot intervals)

3 FOOT CONCRETE L-WALL

Designer: NRCS Maryland.
Drawings: CW-3.3.1L
Issue Date: March, 2004, Revised February 2017
Applications: Maryland Conservation Practice Standard for Waste Storage Facility, code 313.
Assumptions: Grade 60 steel reinforcement.

4,000 psi concrete.

Footing is above high water table, or drainage is provided.

Minimum 4-inch cast-in-place concrete floor at base of wall.

Minimum soil bearing capacity of 2000 psf

Maximum Backfill 3' with maximum 100 psf surcharge on wall.

Minimum Backfill 1'

Manure with an Equivalent Fluid Pressure EFP of 65 lb/ft²/ft of depth.

Backfill Material Backfill material consists of a low to medium-plasticity silts and clays with little sand and/or gravel (50% or more fines). This material has an Equivalent Fluid Pressure EFP of 65 lb/ft²/ft of depth.

Equipment Access Areas

This wall is designed with a 100 psf surcharge on the wall. This is equivalent to the loading for livestock or a small farm tractor (6000 lb GVW).

Bridge Slab

Where equipment larger than that shown above will be present, a different wall design or a bridge slab access pad extending a minimum of 6 feet from the back of the wall must be used.

Materials: Concrete - 0.195 yd³/ft

Reinforcement - #4 Bar 20 lf/ft (Includes vertical overlaps as shown on drawings and horizontal overlap at 20 foot intervals)

3 FOOT CONCRETE L-WALL

Designer: NRCS Maryland.

Drawings: CW-3.3.0L

Issue Date: March, 2004, Revised February, 2017

Applications: Maryland Conservation Practice Standard for Waste Storage Facility, code 313.

Assumptions: Grade 60 steel reinforcement.

4,000 psi concrete.

Footing is above high water table, or drainage is provided.

Minimum 5-inch cast-in-place concrete floor at base of wall. Slab must be placed at same time as footing and extend a minimum of 3 feet from face of footing, as shown in detail.

Minimum soil bearing capacity of 2000 psf

Maximum Backfill 3' with maximum 100 psf surcharge on wall.

Minimum Backfill Level with top of footing.

Manure with an Equivalent Fluid Pressure EFP of 65 lb/ft²/ft of depth.

Backfill Material Backfill material consists of a low to medium-plasticity silts and clays with little sand and/or gravel (50% or more fines). This material has an Equivalent Fluid Pressure EFP of 65 lb/ft²/ft of depth.

Equipment Access Areas

This wall is designed with a 100 psf surcharge on the wall. This is equivalent to the loading for livestock or a small farm tractor (6000 lb GVW).

Bridge Slab

Where equipment larger than that shown above will be present, a different wall design or a bridge slab access pad extending a minimum of 6 feet from the back of the wall must be used.

Materials: Concrete - 0.242 yd³/ft

Reinforcement - #4 Bar 21.5 lf/ft (Includes vertical overlaps as shown on drawings and horizontal overlap at 20 foot intervals)

4 FOOT CONCRETE WALL

Designer: NRCS Maryland.

Drawings: CW-4.4.1

Issue Date: March, 2004, Revised February 2017

Applications: Maryland Conservation Practice Standard for Waste Storage Facility, code 313.

Assumptions: Grade 60 steel reinforcement.

4,000 psi concrete.

Footing is above high water table, or drainage is provided.

Minimum 4-inch cast-in-place concrete floor at base of wall.

Minimum soil bearing capacity of 2000 psf

Maximum Backfill 4' with maximum 100 psf surcharge on wall.

Minimum Backfill 1.5'

Manure with an Equivalent Fluid Pressure EFP of 65 lb/ft²/ft of depth.

Backfill Material Backfill material consists of a low to medium-plasticity silts and clays with little sand and/or gravel (50% or more fines). This material has an Equivalent Fluid Pressure EFP of 65 lb/ft²/ft of depth.

Equipment Access Areas

This wall is designed with a 100 psf surcharge on the wall. This is equivalent to the loading for livestock or a small farm tractor (6000 lb GVW).

Bridge Slab

Where equipment larger than that shown above will be present, a different wall design or a bridge slab access pad extending a minimum of 6 feet from the back of the wall must be used.

Materials: Concrete - 0.207 yd³/ft

Reinforcement - #4 Bar 19.5 lf/ft (Includes vertical overlaps as shown on drawings and horizontal overlap at 20 foot intervals)

4 FOOT CONCRETE WALL

Designer: NRCS Maryland.

Drawings: CW-4.4.0

Issue Date: March, 2004, Revised February, 2017

Applications: Maryland Conservation Practice Standard for Waste Storage Facility, code 313.

Assumptions: Grade 60 steel reinforcement.

4,000 psi concrete.

Footing is above high water table, or drainage is provided.

Minimum 4-inch cast-in-place concrete floor at base of wall.

Minimum soil bearing capacity of 2000 psf

Maximum Backfill 4' with maximum 100 psf surcharge on wall.

Minimum Backfill Level with top of footing.

Manure with an Equivalent Fluid Pressure EFP of 65 lb/ft²/ft of depth.

Backfill Material Backfill material consists of a low to medium-plasticity silts and clays with little sand and/or gravel (50% or more fines). This material has an Equivalent Fluid Pressure EFP of 65 lb/ft²/ft of depth.

Equipment Access Areas

This wall is designed with a 100 psf surcharge on the wall. This is equivalent to the loading for livestock or a small farm tractor (6000 lb GVW).

Bridge Slab

Where equipment larger than that shown above will be present, a different wall design or a bridge slab access pad extending a minimum of 6 feet from the back of the wall must be used.

Materials: Concrete - 0.250 yd³/ft

Reinforcement - #4 Bar 22 lf/ft (Includes vertical overlaps as shown on drawings and horizontal overlap at 20 foot intervals)

4 FOOT CONCRETE L-WALL

Designer: NRCS Maryland.
Drawings: CW-4.4.1L
Issue Date: March, 2004, Revised February, 2017
Applications: Maryland Conservation Practice Standard for Waste Storage Facility, code 313.
Assumptions: Grade 60 steel reinforcement.

4,000 psi concrete.

Footing is above high water table, or drainage is provided.

Minimum 4-inch cast-in-place concrete floor at base of wall.

Minimum soil bearing capacity of 2000 psf

Maximum Backfill 4' with maximum 100 psf surcharge on wall.

Minimum Backfill 1 foot.

Manure with an Equivalent Fluid Pressure EFP of 65 lb/ft²/ft of depth.

Backfill Material Backfill material consists of a low to medium-plasticity silts and clays with little sand and/or gravel (50% or more fines). This material has an Equivalent Fluid Pressure EFP of 65 lb/ft²/ft of depth.

Equipment Access Areas

This wall is designed with a 100 psf surcharge on the wall. This is equivalent to the loading for livestock or a small farm tractor (6000 lb GVW).

Bridge Slab

Where equipment larger than that shown above will be present, a different wall design or a bridge slab access pad extending a minimum of 6 feet from the back of the wall must be used.

Materials: Concrete - 0.269 yd³/ft

Reinforcement - #4 Bar 20 lf/ft

#5 Bar 7 lf/ft

(Includes vertical overlaps as shown on drawings and horizontal overlap at 20 foot intervals)

4 FOOT CONCRETE L-WALL

Designer: NRCS Maryland.

Drawings: CW-4.4.0L

Issue Date: March, 2004, Revised February, 2017

Applications: Maryland Conservation Practice Standard for Waste Storage Facility, code 313.

Assumptions: Grade 60 steel reinforcement.

4,000 psi concrete.

Footing is above high water table, or drainage is provided.

Minimum 5-inch cast-in-place concrete floor at base of wall. Slab must be placed at same time as footing and extend a minimum of 5 feet from face of footing, as shown in detail.

Minimum soil bearing capacity of 2000 psf

Maximum Backfill 4' with maximum 100 psf surcharge on wall.

Minimum Backfill Level with top of footing.

Manure with an Equivalent Fluid Pressure EFP of 65 lb/ft²/ft of depth.

Backfill Material Backfill material consists of a low to medium-plasticity silts and clays with little sand and/or gravel (50% or more fines). This material has an Equivalent Fluid Pressure EFP of 65 lb/ft²/ft of depth.

Equipment Access Areas

This wall is designed with a 100 psf surcharge on the wall. This is equivalent to the loading for livestock or a small farm tractor (6000 lb GVW).

Bridge Slab

Where equipment larger than that shown above will be present, a different wall design or a bridge slab access pad extending a minimum of 6 feet from the back of the wall must be used.

Materials: Concrete - 0.346 yd³/ft

Reinforcement - #4 Bar 27 lf/ft

Includes vertical overlaps as shown on drawings and horizontal overlap at 20 foot intervals)

4 FOOT CONCRETE WALL

Designer: NRCS Maryland.

Drawings: CW-4.4.4R

Issue Date: March, 2004, February, 2017

Applications: Maryland Conservation Practice Standard for Waste Storage Facility, code 313.

Assumptions: Grade 60 steel reinforcement.

4,000 psi concrete.

Footing is above high water table, or drainage is provided.

Minimum 4-inch cast-in-place concrete floor at base of wall.

Minimum soil bearing capacity of 2000 psf

Backfill - 4' with maximum 250 psf surcharge on wall, with the top of wall restrained by a concrete slab.

Manure with an Equivalent Fluid Pressure EFP of 65 lb/ft²/ft of depth.

Backfill Material Backfill material consists of a low to medium-plasticity silts and clays with little sand and/or gravel (50% or more fines). This material has an Equivalent Fluid Pressure EFP of 65 lb/ft²/ft of depth.

Equipment Access Areas

This wall is designed with a 250 psf surcharge on the wall. This is equivalent to the loading for a farm tractor or truck with a gross vehicle weight (GVW) of 16,000 lbs.

Bridge Slab

Where equipment larger than that shown above will be present, a different wall design or a bridge slab access pad extending a minimum of 6 feet from the back of the wall must be used.

Materials: Concrete - 0.269 yd³/ft

Reinforcement - #4 Bar 28 lf/ft

(Includes vertical overlaps as shown on drawings and horizontal overlap at 20 foot intervals)

5 FOOT CONCRETE WALL

Designer: NRCS Maryland.

Drawings: CW-5.5.1

Issue Date: March, 2004, February, 2017

Applications: Maryland Conservation Practice Standard for Waste Storage Facility, code 313.

Assumptions: Grade 60 steel reinforcement.

4,000 psi concrete.

Footing is above high water table, or drainage is provided.

Minimum 4-inch cast-in-place concrete floor at base of wall.

Minimum soil bearing capacity of 2000 psf

Maximum Backfill 5' with maximum 100 psf surcharge on wall.

Minimum Backfill 1.0'

Manure with an Equivalent Fluid Pressure EFP of 65 lb/ft²/ft of depth.

Backfill Material Backfill material consists of a low to medium-plasticity silts and clays with little sand and/or gravel (50% or more fines). This material has an Equivalent Fluid Pressure EFP of 65 lb/ft²/ft of depth.

Equipment Access Areas

This wall is designed with a 100 psf surcharge on the wall. This is equivalent to the loading for livestock or a small farm tractor (6000 lb GVW).

Bridge Slab

Where equipment larger than that shown above will be present, a different wall design or a bridge slab access pad extending a minimum of 7 feet from the back of the wall must be used.

Materials: Concrete - 0.268 yd³/ft

Reinforcement - #4 Bar 19.5 lf/ft

#5 Bar 5.5 lf/ft

(Includes vertical overlaps as shown on drawings and horizontal overlap at 20 foot intervals)

5 FOOT CONCRETE WALL

Designer: NRCS Maryland.
Drawings: CW-5.5.0
Issue Date: March, 2004, February, 2017
Applications: Maryland Conservation Practice Standard for Waste Storage Facility, code 313.
Assumptions: Grade 60 steel reinforcement.

4,000 psi concrete.

Footing is above high water table, or drainage is provided.

Minimum 4-inch cast-in-place concrete floor at base of wall.

Minimum soil bearing capacity of 2000 psf

Maximum Backfill 5' with maximum 100 psf surcharge on wall.

Minimum Backfill Level with top of Footing.

Manure with an Equivalent Fluid Pressure EFP of 65 lb/ft²/ft of depth.

Backfill Material Backfill material consists of a low to medium-plasticity silts and clays with little sand and/or gravel (50% or more fines). This material has an Equivalent Fluid Pressure EFP of 65 lb/ft²/ft of depth.

Equipment Access Areas

This wall is designed with a 100 psf surcharge on the wall. This is equivalent to the loading for livestock or a small farm tractor (6000 lb GVW).

Bridge Slab

Where equipment larger than that shown above will be present, a different wall design or a bridge slab access pad extending a minimum of 7 feet from the back of the wall must be used.

Materials: Concrete - 0.329 yd³/ft
Reinforcement - #4 Bar 21.5 lf/ft

#5 Bar 9 lf/ft

(Includes vertical overlaps as shown on drawings and horizontal overlap at 20 foot intervals)

5 FOOT CONCRETE WALL

Designer: NRCS Maryland.
Drawings: CW-5.5.1L
Issue Date: March, 2004, Revised February, 2017
Applications: Maryland Conservation Practice Standard for Waste Storage Facility, code 313.
Assumptions: Grade 60 steel reinforcement.

4,000 psi concrete.

Footing is above high water table, or drainage is provided.

Minimum 4-inch cast-in-place concrete floor at base of wall.

Minimum soil bearing capacity of 2000 psf

Maximum Backfill 5' with maximum 100 psf surcharge on wall.

Minimum Backfill 1.0'

Manure with an Equivalent Fluid Pressure EFP of 65 lb/ft²/ft of depth.

Backfill Material Backfill material consists of a low to medium-plasticity silts and clays with little sand and/or gravel (50% or more fines). This material has an Equivalent Fluid Pressure EFP of 65 lb/ft²/ft of depth.

Equipment Access Areas

This wall is designed with a 100 psf surcharge on the wall. This is equivalent to the loading for livestock or a small farm tractor (6000 lb GVW).

Bridge Slab

Where equipment larger than that shown above will be present, a different wall design or a bridge slab access pad extending a minimum of 6 feet from the back of the wall must be used.

Materials: Concrete - 0.337 yd³/ft

Reinforcement - #4 Bar 25 lf/ft

#5 Bar 8 lf/ft

(Includes vertical overlaps as shown on drawings and horizontal overlap at 20 foot intervals)

5 FOOT CONCRETE L-WALL

Designer: NRCS Maryland.

Drawings: CW-5.5.0L

Issue Date: March, 2004, Revised February, 2017

Applications: Maryland Conservation Practice Standard for Waste Storage Facility, code 313.

Assumptions: Grade 60 steel reinforcement.

4,000 psi concrete.

Footing is above high water table, or drainage is provided.

Minimum 5-inch cast-in-place concrete floor at base of wall. Slab must be placed at same time as footing and extend a minimum of 8 feet from face of footing, as shown in detail.

Minimum soil bearing capacity of 2000 psf

Maximum Backfill 5' with maximum 100 psf surcharge on wall.

Minimum Backfill Level with top of footing.

Manure with an Equivalent Fluid Pressure EFP of 65 lb/ft²/ft of depth.

Backfill Material Backfill material consists of a low to medium-plasticity silts and clays with little sand and/or gravel (50% or more fines). This material has an Equivalent Fluid Pressure EFP of 65 lb/ft²/ft of depth.

Equipment Access Areas

This wall is designed with a 100 psf surcharge on the wall. This is equivalent to the loading for livestock or a small farm tractor (6000 lb GVW).

Bridge Slab

Where equipment larger than that shown above will be present, a different wall design or a bridge slab access pad extending a minimum of 7 feet from the back of the wall must be used.

Materials: Concrete - 0.460 yd³/ft

Reinforcement - #4 Bar 25 lf/ft

#5 Bar 8 lf/ft

(Includes vertical overlaps as shown on drawings and horizontal overlap at 20 foot intervals)

6 FOOT CONCRETE WALL

Designer: NRCS Maryland.
Drawings: CW-6.6.1
Issue Date: March, 2004, Revised February, 2017
Applications: Maryland Conservation Practice Standard for Waste Storage Facility, code 313.
Assumptions: Grade 60 steel reinforcement.

4,000 psi concrete.

Footing is above high water table, or drainage is provided.

Minimum 4-inch cast-in-place concrete floor at base of wall.

Minimum soil bearing capacity of 2000 psf

Maximum Backfill 6' with maximum 100 psf surcharge on wall.

Minimum Backfill 1.5 Feet.

Manure with an Equivalent Fluid Pressure EFP of 65 lb/ft²/ft of depth.

Backfill Material Backfill material consists of a low to medium-plasticity silts and clays with little sand and/or gravel (50% or more fines). This material has an Equivalent Fluid Pressure EFP of 65 lb/ft²/ft of depth.

Equipment Access Areas

This wall is designed with a 100 psf surcharge on the wall. This is equivalent to the loading for livestock or a small farm tractor (6000 lb GVW).

Bridge Slab

Where equipment larger than that shown above will be present, a different wall design or a bridge slab access pad extending a minimum of 8 feet from the back of the wall must be used.

Materials: Concrete - 0.313 yd³/ft

Reinforcement - #4 Bar 24.5 lf/ft

#5 Bar 9 lf/ft

(Includes vertical overlaps as shown on drawings and horizontal overlap at 20 foot intervals)

6 FOOT CONCRETE WALL

Designer: NRCS Maryland.
Drawings: CW-6.6.0
Issue Date: March, 2004, Revised February, 2017
Applications: Maryland Conservation Practice Standard for Waste Storage Facility, code 313.
Assumptions: Grade 60 steel reinforcement.

4,000 psi concrete.

Footing is above high water table, or drainage is provided.

Minimum 4-inch cast-in-place concrete floor at base of wall.

Minimum soil bearing capacity of 2000 psf

Maximum Backfill 6' with maximum 100 psf surcharge on wall.

Minimum Backfill Level with top of footing.

Manure with an Equivalent Fluid Pressure EFP of 65 lb/ft²/ft of depth.

Backfill Material Backfill material consists of a low to medium-plasticity silts and clays with little sand and/or gravel (50% or more fines). This material has an Equivalent Fluid Pressure EFP of 65 lb/ft²/ft of depth.

Equipment Access Areas

This wall is designed with a 100 psf surcharge on the wall. This is equivalent to the loading for livestock or a small farm tractor (6000 lb GVW).

Bridge Slab

Where equipment larger than that shown above will be present, a different wall design or a bridge slab access pad extending a minimum of 8 feet from the back of the wall must be used.

Materials: Concrete - 0.366 yd³/ft

Reinforcement - #4 Bar 33 lf/ft

(Includes vertical overlaps as shown on drawings and horizontal overlap at 20 foot intervals)

6 FOOT CONCRETE WALL

Designer: NRCS Maryland.
Drawings: CW-6.6.1L
Issue Date: March, 2004, Revised February, 2017
Applications: Maryland Conservation Practice Standard for Waste Storage Facility, code 313.
Assumptions: Grade 60 steel reinforcement.

4,000 psi concrete.

Footing is above high water table, or drainage is provided.

Minimum 4-inch cast-in-place concrete floor at base of wall.

Minimum soil bearing capacity of 2000 psf

Maximum Backfill 6' with maximum 100 psf surcharge on wall.

Minimum Backfill 1.5'

Manure with an Equivalent Fluid Pressure EFP of 65 lb/ft²/ft of depth.

Backfill Material Backfill material consists of a low to medium-plasticity silts and clays with little sand and/or gravel (50% or more fines). This material has an Equivalent Fluid Pressure EFP of 65 lb/ft²/ft of depth.

Equipment Access Areas

This wall is designed with a 100 psf surcharge on the wall. This is equivalent to the loading for livestock or a small farm tractor (6000 lb GVW).

Bridge Slab

Where equipment larger than that shown above will be present, a different wall design or a bridge slab access pad extending a minimum of 8 feet from the back of the wall must be used.

Materials: Concrete - 0.387 yd³/ft

Reinforcement - #4 Bar 29.5 lf/ft

#5 Bar 10 lf/ft

(Includes vertical overlaps as shown on drawings and horizontal overlap at 20 foot intervals)

6 FOOT CONCRETE L-WALL

Designer: NRCS Maryland.

Drawings: CW-6.6.0L

Issue Date: March, 2004, Revised February, 2017

Applications: Maryland Conservation Practice Standard for Waste Storage Facility, code 313.

Assumptions: Grade 60 steel reinforcement.

4,000 psi concrete.

Footing is above high water table, or drainage is provided.

Minimum 5-inch cast-in-place concrete floor at base of wall. Slab must be placed at same time as footing and extend a minimum of 12 feet from face of footing, as shown in detail.

Minimum soil bearing capacity of 2000 psf

Maximum Backfill 5' with maximum 100 psf surcharge on wall.

Minimum Backfill Level with top of footing.

Manure with an Equivalent Fluid Pressure EFP of 65 lb/ft²/ft of depth.

Backfill Material Backfill material consists of a low to medium-plasticity silts and clays with little sand and/or gravel (50% or more fines). This material has an Equivalent Fluid Pressure EFP of 65 lb/ft²/ft of depth.

Equipment Access Areas

This wall is designed with a 100 psf surcharge on the wall. This is equivalent to the loading for livestock or a small farm tractor (6000 lb GVW).

Bridge Slab

Where equipment larger than that shown above will be present, a different wall design or a bridge slab access pad extending a minimum of 8 feet from the back of the wall must be used.

Materials: Concrete - 0.451 yd³/ft

Reinforcement - #4 Bar 29.5 lf/ft

#5 Bar 10 lf/ft

(Includes vertical overlaps as shown on drawings and horizontal overlap at 20 foot intervals)

6 FOOT CONCRETE WALL

Designer: NRCS Maryland.
Drawings: CW-6.6.6R
Issue Date: March, 2004, February, 2017
Applications: Maryland Conservation Practice Standard for Waste Storage Facility, code 313.
Assumptions: Grade 60 steel reinforcement.

4,000 psi concrete.

Footing is above high water table, or drainage is provided.

Minimum 4-inch cast-in-place concrete floor at base of wall.

Minimum soil bearing capacity of 2000 psf

Backfill - 6' with maximum 250 psf surcharge on wall, with the top of wall restrained by a concrete slab.

Manure with an Equivalent Fluid Pressure EFP of 65 lb/ft²/ft of depth.

Backfill Material Backfill material consists of a low to medium-plasticity silts and clays with little sand and/or gravel (50% or more fines). This material has an Equivalent Fluid Pressure EFP of 65 lb/ft²/ft of depth.

Equipment Access Areas

This wall is designed with a 250 psf surcharge on the wall. This is equivalent to the loading for a farm tractor or truck with a gross vehicle weight (GVW) of 16,000 lbs.

Bridge Slab

Where equipment larger than that shown above will be present, a different wall design or a bridge slab access pad extending a minimum of 8 feet from the back of the wall must be used.

Materials: Concrete - 0.302 yd³/ft
Reinforcement - #4 Bar 30.5 lf/ft

#5 Bar 16 lf/ft

(Includes vertical overlaps as shown on drawings and horizontal overlap at 20 foot intervals)

7 FOOT CONCRETE WALL

Designer: NRCS Maryland.

Drawings: CW-7.7.2

Issue Date: March, 2004

Applications: Maryland Conservation Practice Standard for Waste Storage Facility, code 313.

Assumptions: Grade 60 steel reinforcement.

4,000 psi concrete.

Footing is above high water table, or drainage is provided.

Minimum 4-inch cast-in-place concrete floor at base of wall.

Minimum soil bearing capacity of 2000 psf

Maximum Backfill 7' with maximum 100 psf surcharge on wall.

Minimum Backfill 2 feet.

Manure with an Equivalent Fluid Pressure EFP of 65 lb/ft²/ft of depth.

Backfill Material Backfill material consists of a low to medium-plasticity silts and clays with little sand and/or gravel (50% or more fines). This material has an Equivalent Fluid Pressure EFP of 65 lb/ft²/ft of depth.

Equipment Access Areas

This wall is designed with a 100 psf surcharge on the wall. This is equivalent to the loading for livestock or a small farm tractor (6000 lb GVW).

Bridge Slab

Where equipment larger than that shown above will be present, a different wall design or a bridge slab access pad extending a minimum of 9 feet from the back of the wall must be used.

Materials: Concrete - 0.379 yd³/ft

Reinforcement - #4 Bar 25 lf/ft

#5 Bar 15.5 lf/ft

(Includes vertical overlaps as shown on drawings and horizontal overlap at 20 foot intervals)

7 FOOT CONCRETE WALL

Designer: NRCS Maryland.
Drawings: CW-7.7.0
Issue Date: March, 2004, Revised February, 2017
Applications: Maryland Conservation Practice Standard for Waste Storage Facility, code 313.
Assumptions: Grade 60 steel reinforcement.

4,000 psi concrete.

Footing is above high water table, or drainage is provided.

Minimum 4-inch cast-in-place concrete floor at base of wall.

Minimum soil bearing capacity of 2000 psf

Maximum Backfill 7' with maximum 100 psf surcharge on wall.

Minimum Backfill Level with top of footing.

Manure with an Equivalent Fluid Pressure EFP of 65 lb/ft²/ft of depth.

Backfill Material Backfill material consists of a low to medium-plasticity silts and clays with little sand and/or gravel (50% or more fines). This material has an Equivalent Fluid Pressure EFP of 65 lb/ft²/ft of depth.

Equipment Access Areas

This wall is designed with a 100 psf surcharge on the wall. This is equivalent to the loading for livestock or a small farm tractor (6000 lb GVW).

Bridge Slab

Where equipment larger than that shown above will be present, a different wall design or a bridge slab access pad extending a minimum of 9 feet from the back of the wall must be used.

Materials: Concrete - 0.503 yd³/ft

Reinforcement - #4 Bar 30 lf/ft

#5 Bar 12.5 lf/ft

(Includes vertical overlaps as shown on drawings and horizontal overlap at 20 foot intervals)

8 FOOT CONCRETE WALL

Designer: NRCS Maryland.

Drawings: CW-8.8.2

Issue Date: March, 2004, Revised February, 2017

Applications: Maryland Conservation Practice Standard for Waste Storage Facility, code 313.

Assumptions: Grade 60 steel reinforcement.

4,000 psi concrete.

Footing is above high water table, or drainage is provided.

Minimum 4-inch cast-in-place concrete floor at base of wall.

Minimum soil bearing capacity of 2000 psf

Maximum Backfill 8' with maximum 100 psf surcharge on wall.

Minimum Backfill 2 feet.

Manure with an Equivalent Fluid Pressure EFP of 65 lb/ft²/ft of depth.

Backfill Material Backfill material consists of a low to medium-plasticity silts and clays with little sand and/or gravel (50% or more fines). This material has an Equivalent Fluid Pressure EFP of 65 lb/ft²/ft of depth.

Equipment Access Areas

This wall is designed with a 100 psf surcharge on the wall. This is equivalent to the loading for livestock or a small farm tractor (6000 lb GVW).

Bridge Slab

Where equipment larger than that shown above will be present, a different wall design or a bridge slab access pad extending a minimum of 10 feet from the back of the wall must be used.

Materials: Concrete - 0.469 yd³/ft

Reinforcement - #4 Bar 13 lf/ft

#5 Bar 15.5 lf/ft

#6 Bar 38 lf/ft

(Includes vertical overlaps as shown on drawings and horizontal overlap at 20 foot intervals)

8 FOOT CONCRETE WALL

Designer: NRCS Maryland.
Drawings: CW-8.8.0
Issue Date: March, 2004, Revised February, 2017
Applications: Maryland Conservation Practice Standard for Waste Storage Facility, code 313.
Assumptions: Grade 60 steel reinforcement.

4,000 psi concrete.

Footing is above high water table, or drainage is provided.

Minimum 4-inch cast-in-place concrete floor at base of wall.

Minimum soil bearing capacity of 2000 psf

Maximum Backfill 8' with maximum 100 psf surcharge on wall.

Minimum Backfill Level with top of footing.

Manure with an Equivalent Fluid Pressure EFP of 65 lb/ft²/ft of depth.

Backfill Material Backfill material consists of a low to medium-plasticity silts and clays with little sand and/or gravel (50% or more fines). This material has an Equivalent Fluid Pressure EFP of 65 lb/ft²/ft of depth.

Equipment Access Areas

This wall is designed with a 100 psf surcharge on the wall. This is equivalent to the loading for livestock or a small farm tractor (6000 lb GVW).

Bridge Slab

Where equipment larger than that shown above will be present, a different wall design or a bridge slab access pad extending a minimum of 10 feet from the back of the wall must be used.

Materials: Concrete - 0.652 yd³/ft

Reinforcement - #4 Bar 13.5 lf/ft

#5 Bar 17.5 lf/ft

#6 Bar 42 lf/ft

(Includes vertical overlaps as shown on drawings and horizontal overlap at 20 foot intervals)

8 FOOT CONCRETE WALL

Designer: NRCS Maryland.

Drawings: CW-8.8.8R

Issue Date: March, 2004, Revised February 2017

Applications: Maryland Conservation Practice Standard for Waste Storage Facility, code 313.

Assumptions: Grade 60 steel reinforcement.

4,000 psi concrete.

Footing is above high water table, or drainage is provided.

Minimum 4-inch cast-in-place concrete floor at base of wall.

Minimum soil bearing capacity of 2000 psf

Backfill - 8' with maximum 250 psf surcharge on wall, with the top of wall restrained by a concrete slab.

Manure with an Equivalent Fluid Pressure EFP of 65 lb/ft²/ft of depth.

Backfill Material Backfill material consists of a low to medium-plasticity silts and clays with little sand and/or gravel (50% or more fines). This material has an Equivalent Fluid Pressure EFP of 65 lb/ft²/ft of depth.

Equipment Access Areas

This wall is designed with a 250 psf surcharge on the wall. This is equivalent to the loading for a farm tractor or truck with a gross vehicle weight (GVW) of 16,000 lbs.

Bridge Slab

Where equipment larger than that shown above will be present, a different wall design or a bridge slab access pad extending a minimum of 10 feet from the back of the wall must be used.

Materials: Concrete - 0.549 yd³/ft

Reinforcement - #4 Bar 21.5 lf/ft

#5 Bar 16 lf/ft

#6 Bar 35 lf/ft

(Includes vertical overlaps as shown on drawings and horizontal overlap at 20 foot intervals)

10 FOOT CONCRETE WALL

Designer: NRCS Maryland.
Drawings: CW-10.10.3
Issue Date: March, 2004, Revised February, 2017
Applications: Maryland Conservation Practice Standard for Waste Storage Facility, code 313.
Assumptions: Grade 60 steel reinforcement.

4,000 psi concrete.

Footing is above high water table, or drainage is provided.

Minimum 4-inch cast-in-place concrete floor at base of wall.

Minimum soil bearing capacity of 2000 psf

Maximum Backfill 10' with maximum 100 psf surcharge on wall.

Minimum Backfill 3 feet.

Manure with an Equivalent Fluid Pressure EFP of 65 lb/ft²/ft of depth.

Backfill Material Backfill material consists of a low to medium-plasticity silts and clays with little sand and/or gravel (50% or more fines). This material has an Equivalent Fluid Pressure EFP of 65 lb/ft²/ft of depth.

Equipment Access Areas

This wall is designed with a 100 psf surcharge on the wall. This is equivalent to the loading for livestock or a small farm tractor (6000 lb GVW).

Bridge Slab

Where equipment larger than that shown above will be present, a different wall design or a bridge slab access pad extending a minimum of 12 feet from the back of the wall must be used.

Materials: Concrete - 0.688 yd³/ft

Reinforcement - #4 Bar 32 lf/ft

#5 Bar 20 lf/ft

#6 Bar 18 lf/ft

#7 Bar 13 lf/ft

(Includes vertical overlaps as shown on drawings and horizontal overlap at 20 foot intervals)

10 FOOT CONCRETE WALL

Designer: NRCS Maryland.
Drawings: CW-10.10.0
Issue Date: March, 2004, Revised February, 2017
Applications: Maryland Conservation Practice Standard for Waste Storage Facility, code 313.
Assumptions: Grade 60 steel reinforcement.

4,000 psi concrete.

Footing is above high water table, or drainage is provided.

Minimum 4-inch cast-in-place concrete floor at base of wall.

Minimum soil bearing capacity of 2000 psf

Maximum Backfill 10' with maximum 100 psf surcharge on wall.

Minimum Backfill Level with top of footing.

Manure with an Equivalent Fluid Pressure EFP of 65 lb/ft²/ft of depth.

Backfill Material Backfill material consists of a low to medium-plasticity silts and clays with little sand and/or gravel (50% or more fines). This material has an Equivalent Fluid Pressure EFP of 65 lb/ft²/ft of depth.

Equipment Access Areas

This wall is designed with a 100 psf surcharge on the wall. This is equivalent to the loading for livestock or a small farm tractor (6000 lb GVW).

Bridge Slab

Where equipment larger than that shown above will be present, a different wall design or a bridge slab access pad extending a minimum of 12 feet from the back of the wall must be used.

Materials: Concrete - 0.877 yd³/ft

Reinforcement - #4 Bar 38 lf/ft

#5 Bar 22 lf/ft

#6 Bar 20 lf/ft

#7 Bar 16 lf/ft

(Includes vertical overlaps as shown on drawings and horizontal overlap at 20 foot intervals)

10 FOOT CONCRETE WALL

Designer: NRCS Maryland.

Drawings: CW-10.10.10R

Issue Date: March, 2004

Applications: Maryland Conservation Practice Standard for Waste Storage Facility, code 313.

Assumptions: Grade 60 steel reinforcement.

4,000 psi concrete.

Footing is above high water table, or drainage is provided.

Minimum 4-inch cast-in-place concrete floor at base of wall.

Minimum soil bearing capacity of 2000 psf

Backfill - 10' with maximum 250 psf surcharge on wall, with the top of wall restrained by a concrete slab.

Manure with an Equivalent Fluid Pressure EFP of 65 lb/ft²/ft of depth.

Backfill Material Backfill material consists of a low to medium-plasticity silts and clays with little sand and/or gravel (50% or more fines). This material has an Equivalent Fluid Pressure EFP of 65 lb/ft²/ft of depth.

Equipment Access Areas

This wall is designed with a 250 psf surcharge on the wall. This is equivalent to the loading for a farm tractor or truck with a gross vehicle weight (GVW) of 16,000 lbs.

Bridge Slab

Where equipment larger than that shown above will be present, a different wall design or a bridge slab access pad extending a minimum of 12 feet from the back of the wall must be used.

Materials: Concrete - 0.891 yd³/ft

Reinforcement - #4 Bar 29 lf/ft

#5 Bar 22 lf/ft

#6 Bar 57 lf/ft

(Includes vertical overlaps as shown on drawings and horizontal overlap at 20 foot intervals)

12 FOOT CONCRETE WALL

Designer: NRCS Maryland.

Drawings: CW-12.12.4

Issue Date: March, 2004

Applications: Maryland Conservation Practice Standard for Waste Storage Facility, code 313.

Assumptions: Grade 60 steel reinforcement.

4,000 psi concrete.

Footing is above high water table, or drainage is provided.

Minimum 4-inch cast-in-place concrete floor at base of wall.

Minimum soil bearing capacity of 2000 psf

Maximum Backfill 12' with maximum 100 psf surcharge on wall.

Minimum Backfill 4 feet.

Manure with an Equivalent Fluid Pressure EFP of 65 lb/ft²/ft of depth.

Backfill Material Backfill material consists of a low to medium-plasticity silts and clays with little sand and/or gravel (50% or more fines). This material has an Equivalent Fluid Pressure EFP of 65 lb/ft²/ft of depth.

Equipment Access Areas

This wall is designed with a 100 psf surcharge on the wall. This is equivalent to the loading for livestock or a small farm tractor (6000 lb GVW).

Bridge Slab

Where equipment larger than that shown above will be present, a different wall design or a bridge slab access pad extending a minimum of 14 feet from the back of the wall must be used.

Materials: Concrete - 1.127 yd³/ft

Reinforcement - #4 Bar 53 lf/ft

#6 Bar 46 lf/ft

#8 Bar 14 lf/ft

(Includes vertical overlaps as shown on drawings and horizontal overlap at 20 foot intervals)

12 FOOT CONCRETE WALL

Designer: NRCS Maryland.

Drawings: CW-12.12.0

Issue Date: March, 2004

Applications: Maryland Conservation Practice Standard for Waste Storage Facility, code 313.

Assumptions: Grade 60 steel reinforcement.

4,000 psi concrete.

Footing is above high water table, or drainage is provided.

Minimum 4-inch cast-in-place concrete floor at base of wall.

Minimum soil bearing capacity of 2000 psf

Maximum Backfill 12' with maximum 100 psf surcharge on wall.

Minimum Backfill Level with top of footing.

Manure with an Equivalent Fluid Pressure EFP of 65 lb/ft²/ft of depth.

Backfill Material Backfill material consists of a low to medium-plasticity silts and clays with little sand and/or gravel (50% or more fines). This material has an Equivalent Fluid Pressure EFP of 65 lb/ft²/ft of depth.

Equipment Access Areas

This wall is designed with a 100 psf surcharge on the wall. This is equivalent to the loading for livestock or a small farm tractor (6000 lb GVW).

Bridge Slab

Where equipment larger than that shown above will be present, a different wall design or a bridge slab access pad extending a minimum of 14 feet from the back of the wall must be used.

Materials: Concrete - 1.423 yd³/ft

Reinforcement - #4 Bar 53 lf/ft

#6 Bar 46 lf/ft

#8 Bar 14 lf/ft

(Includes vertical overlaps as shown on drawings and horizontal overlap at 20 foot intervals)

12 FOOT CONCRETE WALL

Designer: NRCS Maryland.

Drawings: CW-12.12.12R

Issue Date: March, 2004

Applications: Maryland Conservation Practice Standard for Waste Storage Facility, code 313.

Assumptions: Grade 60 steel reinforcement.

4,000 psi concrete.

Footing is above high water table, or drainage is provided.

Minimum 4-inch cast-in-place concrete floor at base of wall.

Minimum soil bearing capacity of 2000 psf

Backfill - 12' with maximum 250 psf surcharge on wall, with the top of wall restrained by a concrete slab.

Manure with an Equivalent Fluid Pressure EFP of 65 lb/ft²/ft of depth.

Backfill Material Backfill material consists of a low to medium-plasticity silts and clays with little sand and/or gravel (50% or more fines). This material has an Equivalent Fluid Pressure EFP of 65 lb/ft²/ft of depth.

Equipment Access Areas

This wall is designed with a 250 psf surcharge on the wall. This is equivalent to the loading for a farm tractor or truck with a gross vehicle weight (GVW) of 16,000 lbs.

Bridge Slab

Where equipment larger than that shown above will be present, a different wall design or a bridge slab access pad extending a minimum of 14 feet from the back of the wall must be used.

Materials: Concrete - 1.313 yd³/ft

Reinforcement - #4 Bar 65 lf/ft

#6 Bar 71 lf/ft

(Includes vertical overlaps as shown on drawings and horizontal overlap at 20 foot intervals)

SECTION IV

Appendix (Standard Detail Drawings for Use in Maryland)

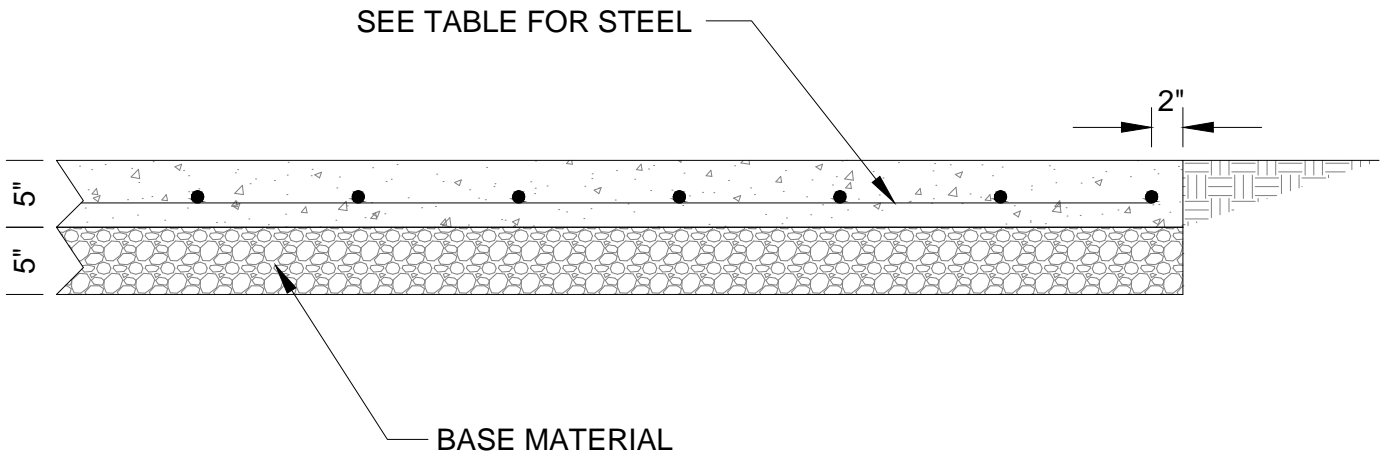

NOT TO SCALE

NOTES:

- 1) 4000 PSI Concrete
- 2) Grade 60 Steel

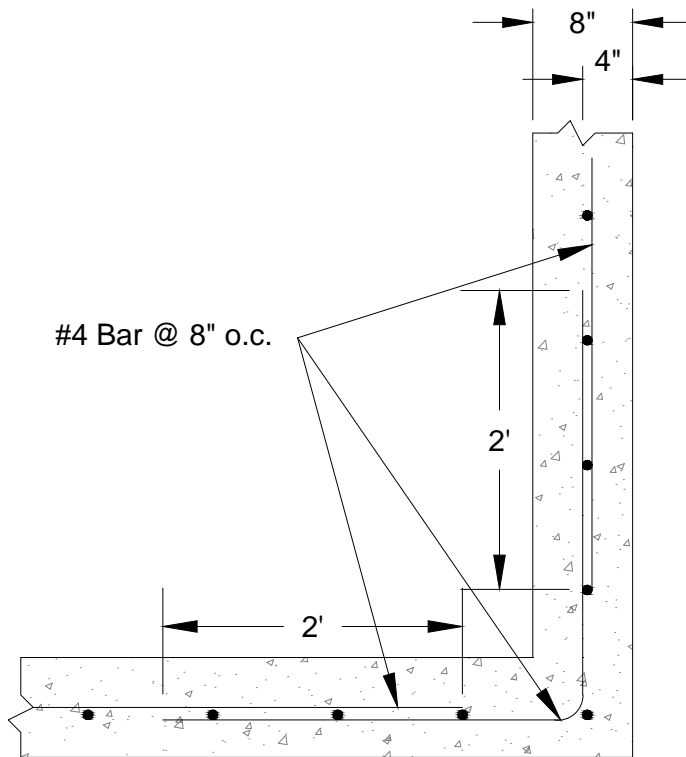

#4 Bar @ 8" o.c.

TOP VIEW

8" RETAINING WALL CORNER

NTS

Notes:

- 1) 4000 psi concrete
- 2) Grade 60 steel

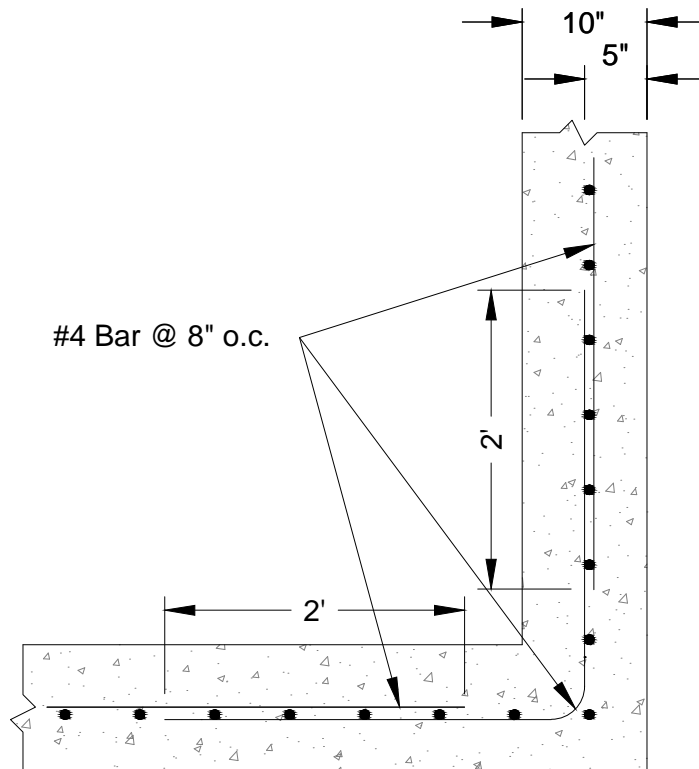

#4 Bar @ 8" o.c.

TOP VIEW

10" RETAINING WALL CORNER

NTS

Notes:

- 1) 4000 psi concrete
- 2) Grade 60 steel



UNITED STATES
DEPARTMENT OF
AGRICULTURE

NATURAL RESOURCES CONSERVATION SERVICE
MARYLAND

WALL DESIGNS AND DETAILS FOR WASTE STORAGE

DRAWING NO. CW-C10

ISSUE DATE: 1/2017

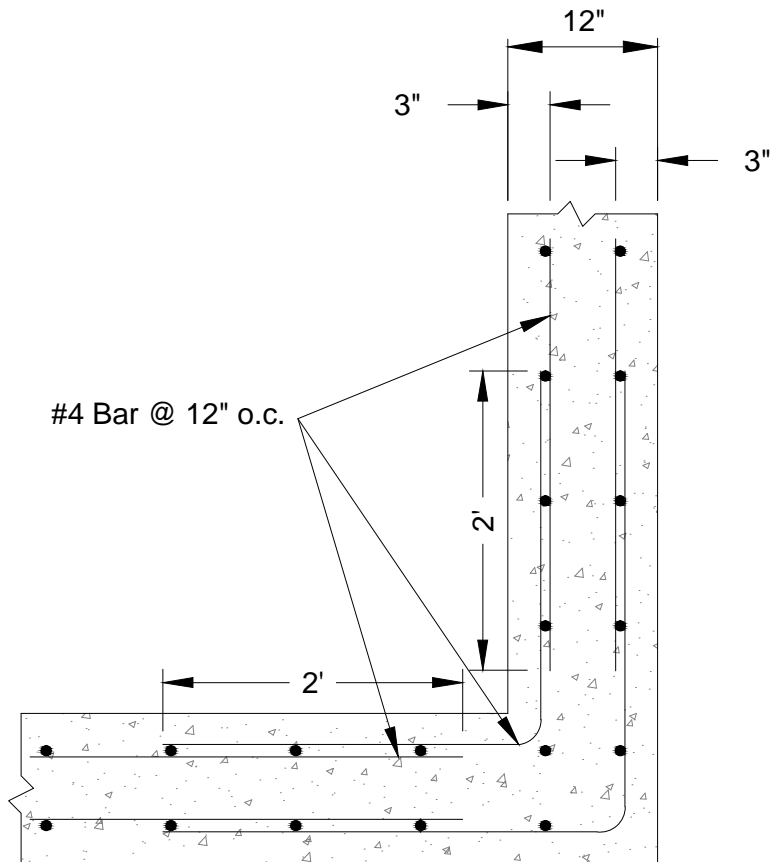

TOP VIEW

12" RETAINING WALL CORNER

NTS

Notes:

- 1) 4000 psi concrete
- 2) Grade 60 steel

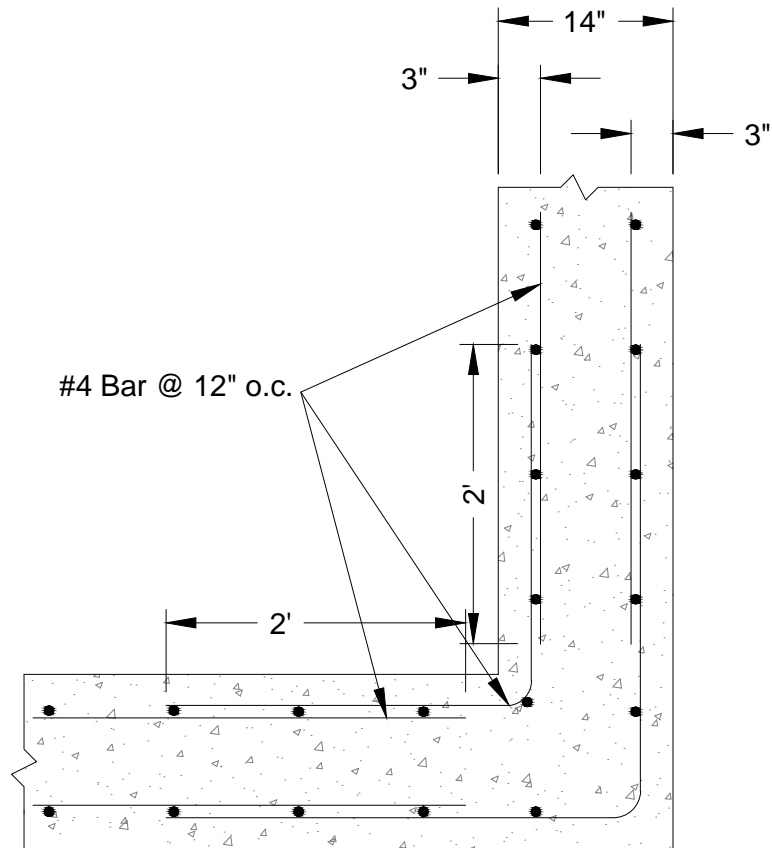

TOP VIEW

14" RETAINING WALL CORNER

NTS

Notes:

- 1) 4000 psi concrete
- 2) Grade 60 steel

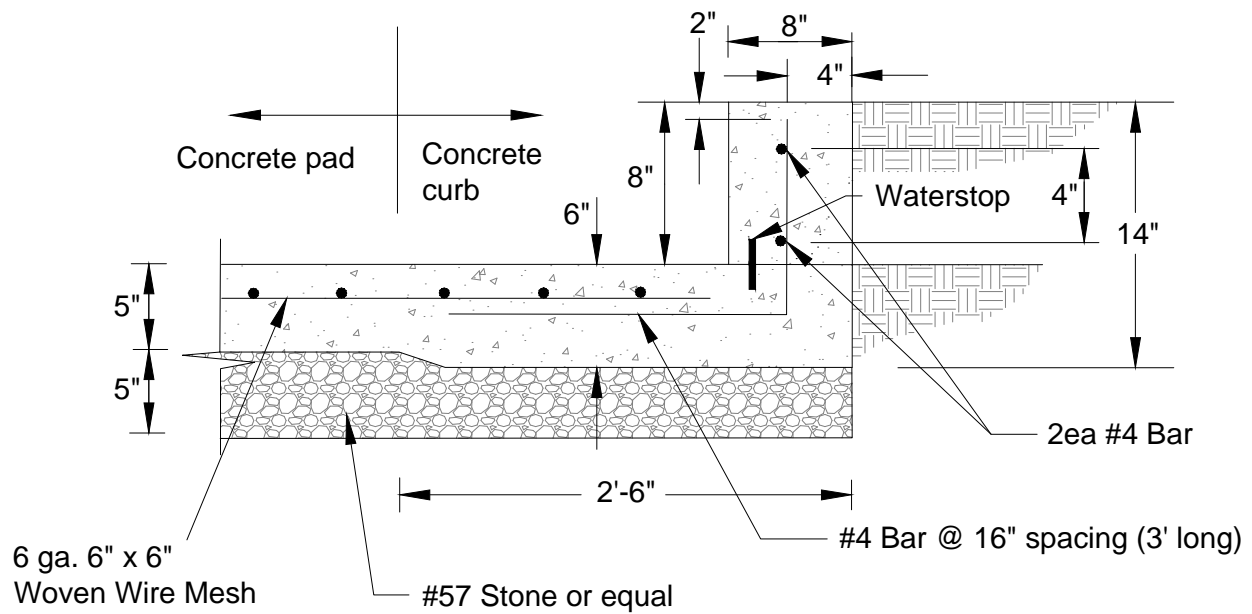

8" CONCRETE CURB

NTS

NOTE: If concrete pad is poured first and concrete curb poured on top of pad, waterstop is to be used. If concrete pad and concrete curb is poured as one continuous pour, the waterstop may be omitted.

Notes:

- 1) 4000 psi concrete
- 2) Grade 60 steel
- 3) Maximum backfill to top of curb
- 4) Minimum backfill to top of floor

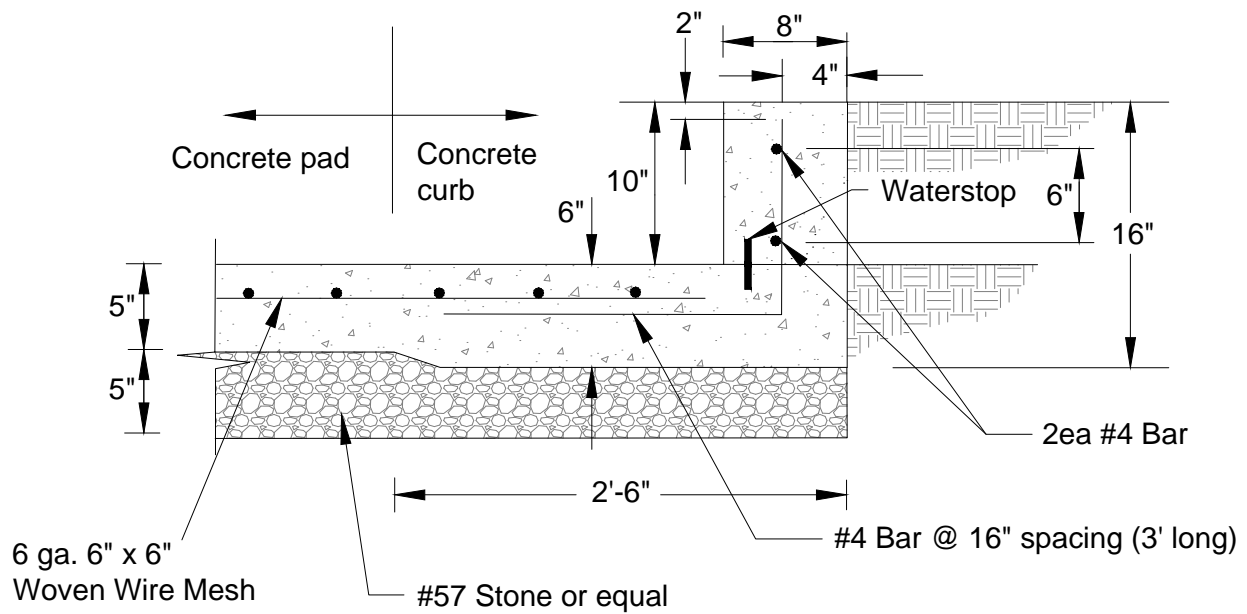

10" CONCRETE CURB

NTS

NOTE: If concrete pad is poured first and concrete curb poured on top of pad, waterstop is to be used. If concrete pad and concrete curb is poured as one continuous pour, the waterstop may be omitted.

Notes:

- 1) 4000 psi concrete
- 2) Grade 60 steel
- 3) Maximum backfill to top of curb
- 4) Minimum backfill to top of floor

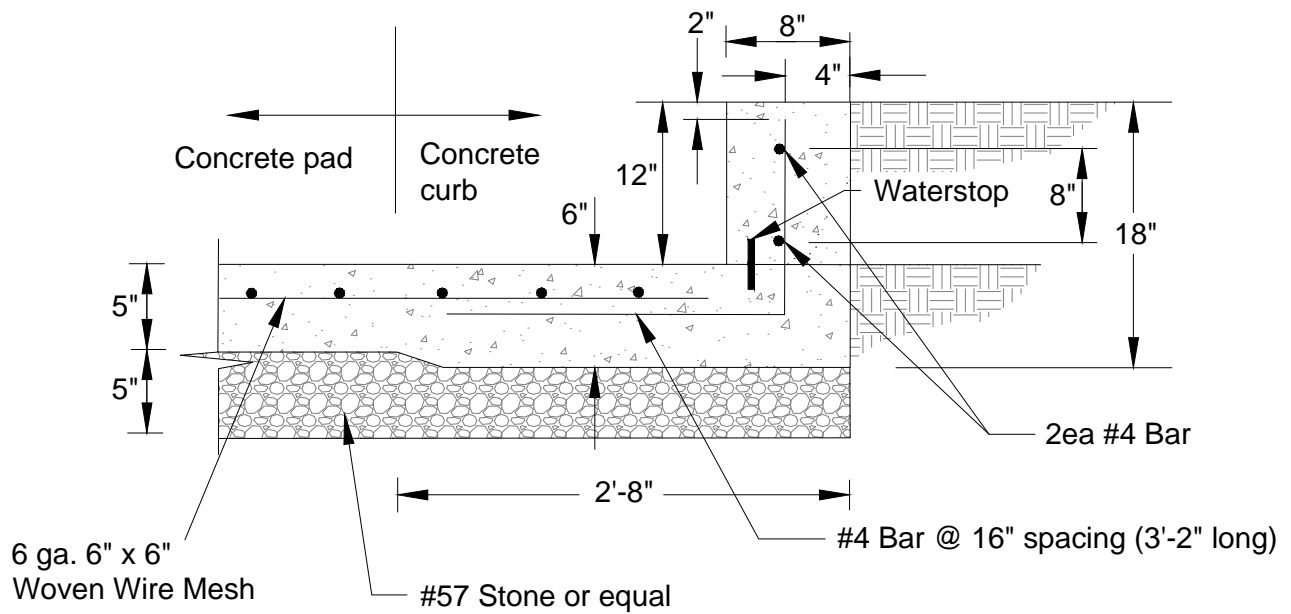

12" CONCRETE CURB

NTS

NOTE: If concrete pad is poured first and concrete curb poured on top of pad, waterstop is to be used. If concrete pad and concrete curb is poured as one continuous pour, the waterstop may be omitted.

Notes:

- 1) 4000 psi concrete
- 2) Grade 60 steel
- 3) Maximum backfill to top of curb
- 4) Minimum backfill to top of floor

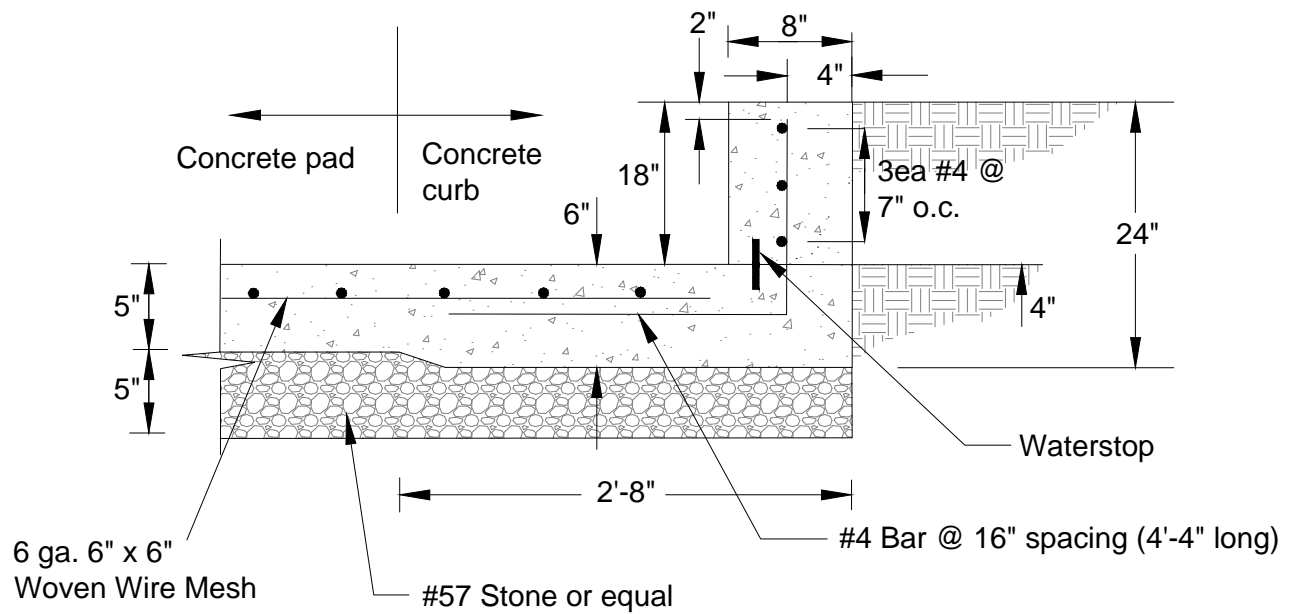

18" CONCRETE CURB

NTS

NOTE: If concrete pad is poured first and concrete curb poured on top of pad, waterstop is to be used. If concrete pad and concrete curb is poured as one continuous pour, the waterstop may be omitted.

Notes:

- 1) 4000 psi concrete
- 2) Grade 60 steel
- 3) Maximum backfill to top of curb
- 4) Minimum backfill to top of floor

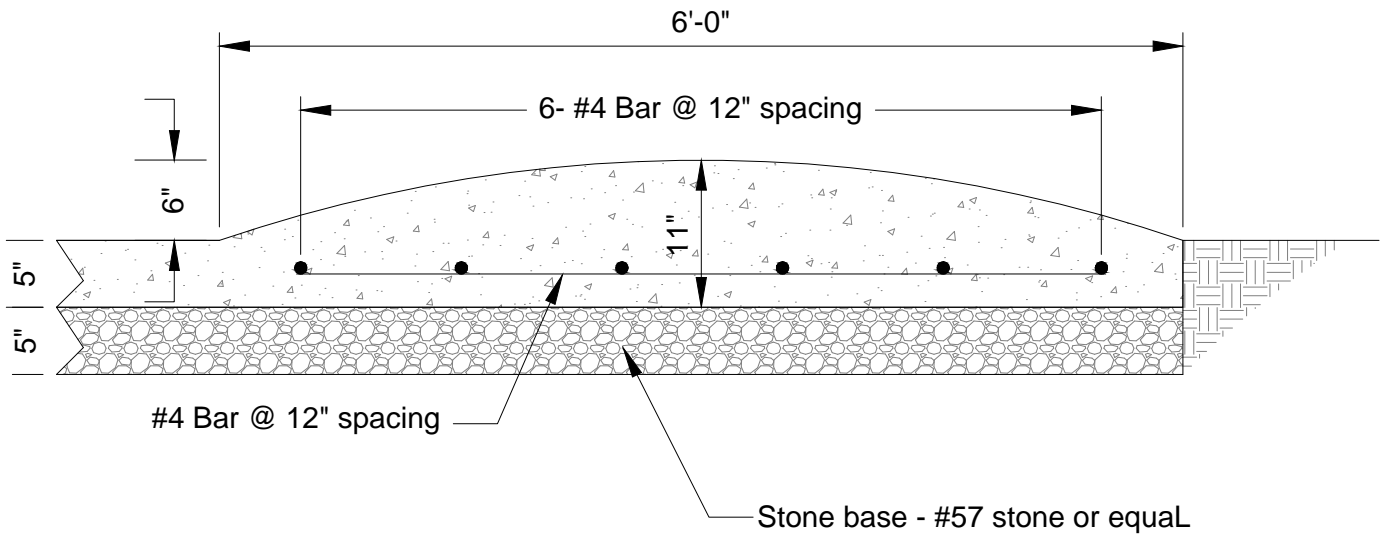

NOT TO SCALE

NOTES:

- 1) 4000 PSI concrete
- 2) Grade 60 steel
- 3) Maximum backfill to top of curb
- 4) Minimum backfill to top of floor

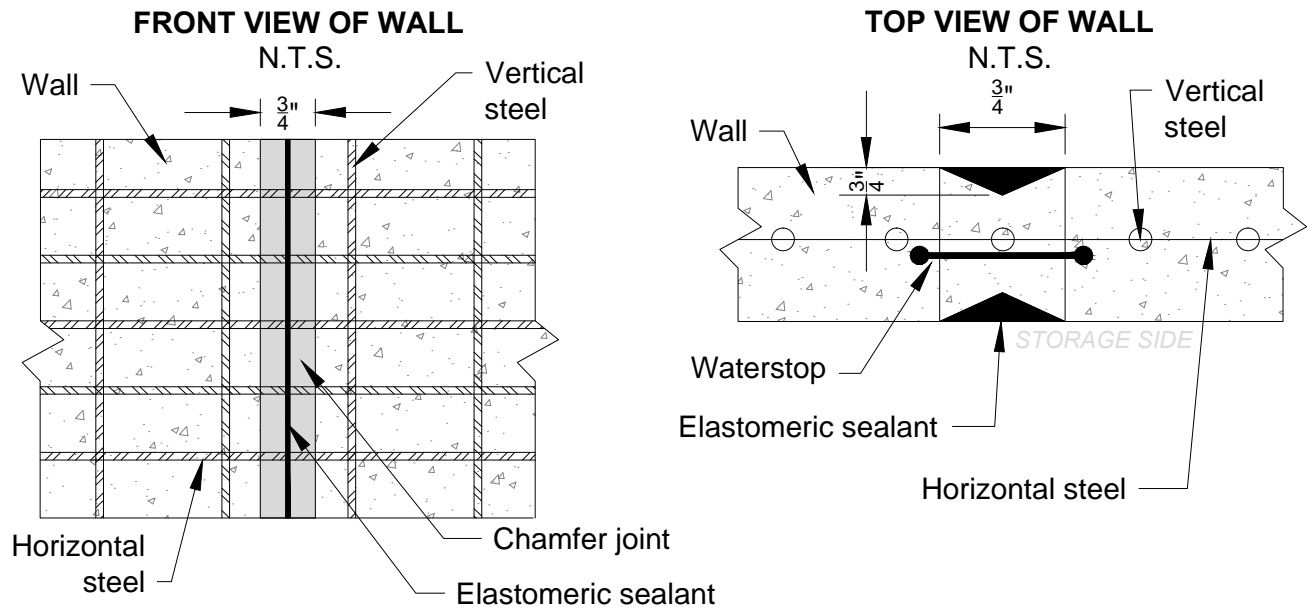

VERTICAL WALL SAW CUT DETAIL

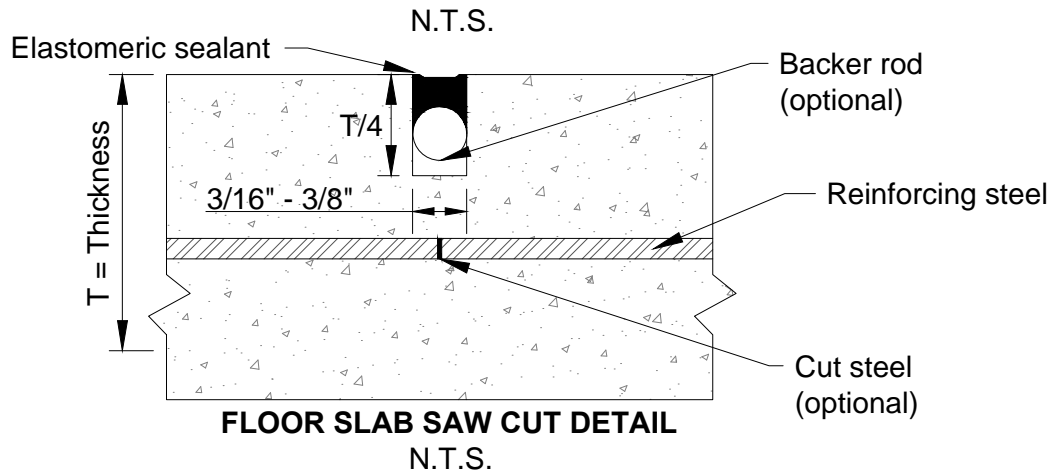

FLOOR SLAB SAW CUT DETAIL

N.T.S.

JOINT PLACEMENT REQUIREMENTS:(VERTICAL)

1. Must be used on any wall 2ft and over in height.
2. Space vertical crack control no greater than 60ft apart or as noted on the plan and do not locate at column anchor.
3. Every other horizontal steel bar (50%) shall be cut at the controlled crack joint.
4. Elastomeric sealant shall be installed on inside and outside of wall where controlled crack joint is placed. Installation of vinyl waterstop is recommended.
5. Follow manufacturer's recommendations for installation of the elastomeric sealer.

JOINT PLACEMENT REQUIREMENTS:(SLAB)

1. Joints shall be cut as soon as aggregate is set, but no later than 24 hours after the concrete placement.
2. Space joints no greater than 60 feet or as shown on design.
3. The saw cut depth shall be a minimum of $\frac{1}{4}$ the thickness of the concrete, to a maximum of 2".
4. Cut 50% of the reinforcing steel **directly** at the joint.(optional)
5. Follow manufacturer's recommendations for installation of the elastomeric sealer.

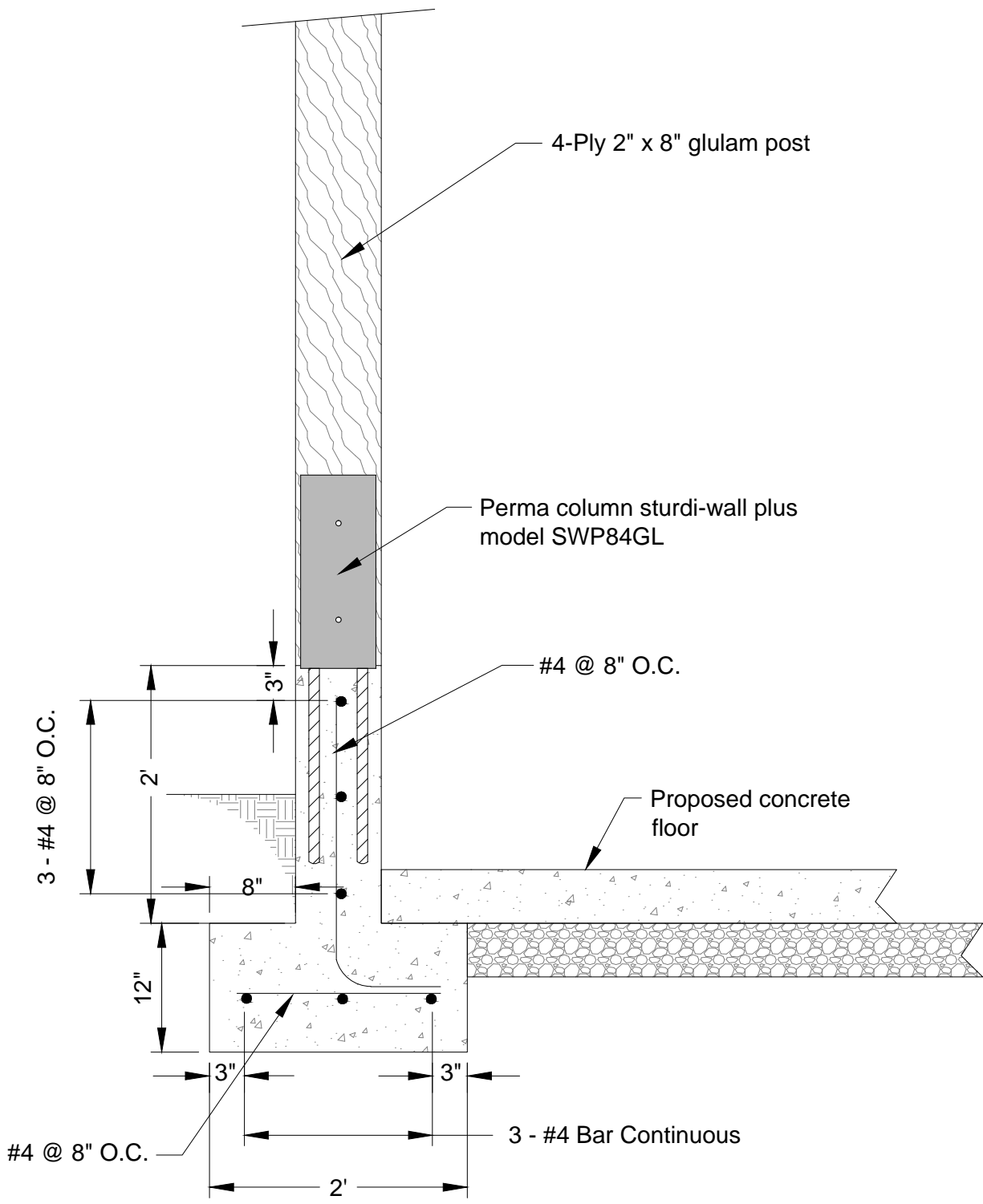

2' RETAINING WALL WITH POST ON TOP

NTS

Notes:

- 1) 4000 psi concrete
- 2) Grade 60 steel
- 3) Minimum backfill of 12" required

 <p>UNITED STATES DEPARTMENT OF AGRICULTURE</p> <p>NATURAL RESOURCES CONSERVATION SERVICE MARYLAND</p>	<p>WALL DESIGNS AND DETAILS FOR WASTE STORAGE</p>	DRAWING NO. CW-2.2.1W
		ISSUE DATE: 1/2017

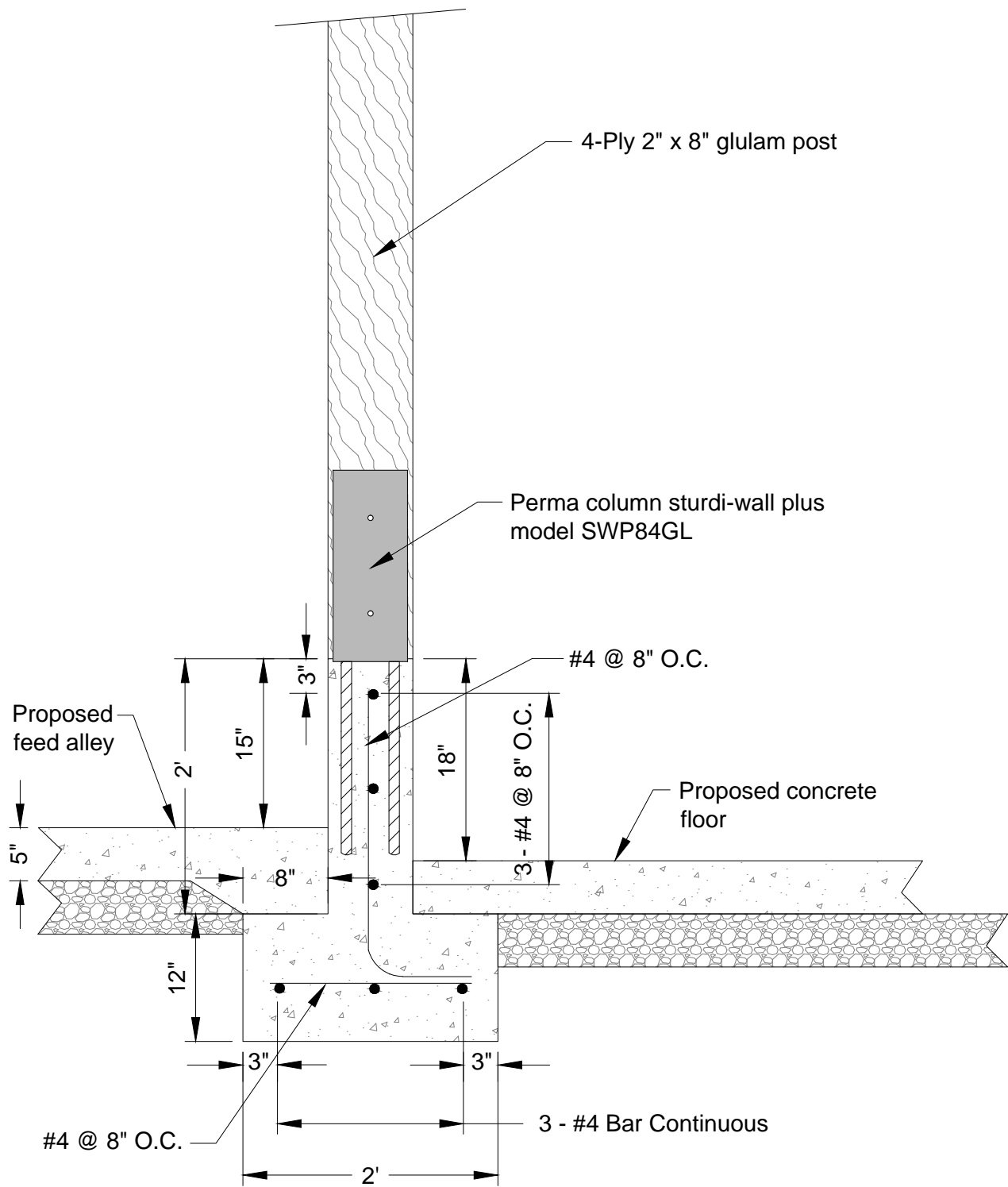

2' RETAINING WALL WITH POST ON TOP

NTS

Notes:

- 1) 4000 psi concrete
- 2) Grade 60 steel

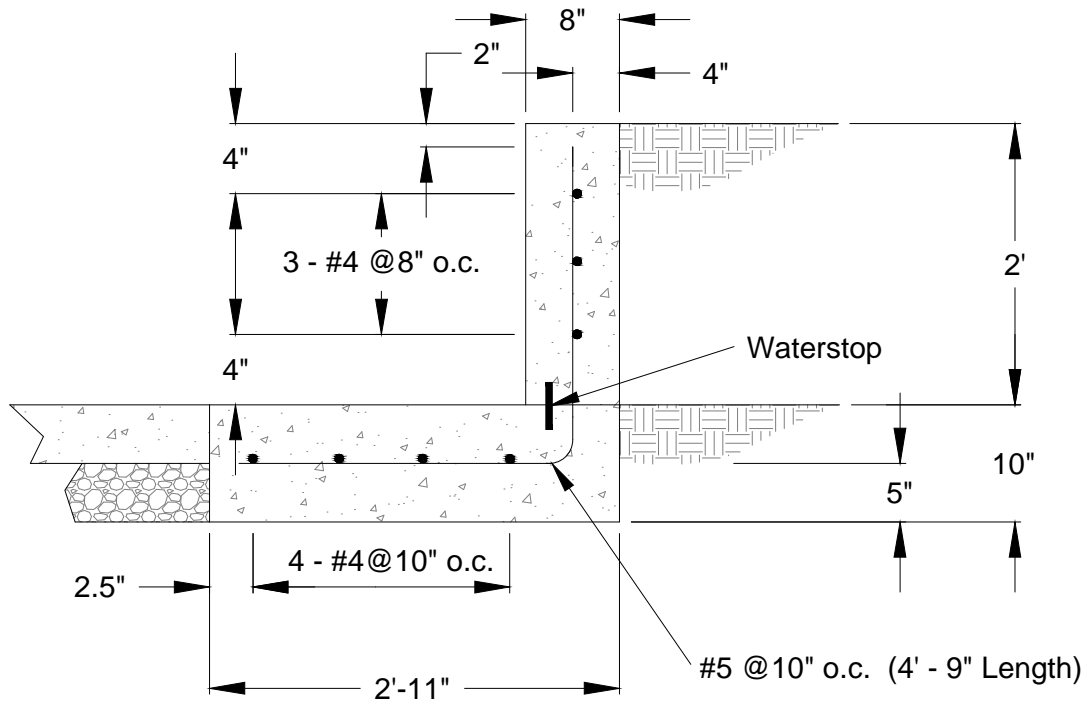

2' RETAINING WALL

NTS

Notes:

- 1) 4000 psi concrete
- 2) Grade 60 steel
- 3) Maximum backfill top of wall (2')
- 4) Minimum backfill to top of floor
- 5) Concrete slab must be placed before wall is backfilled
- 6) Maximum surcharge 100 PSF

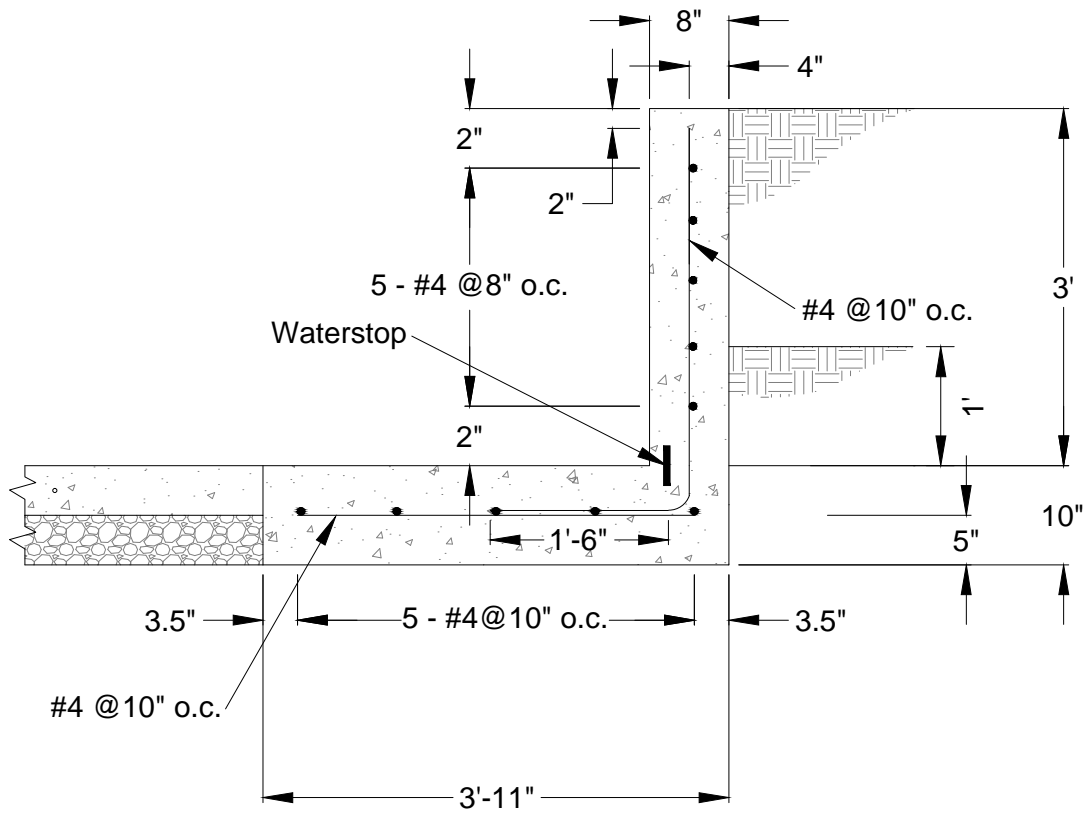

3' RETAINING WALL

NTS

Notes:

- 1) 4000 psi concrete
- 2) Grade 60 steel
- 3) Maximum backfill top of wall (3')
- 4) Minimum backfill 1'
- 5) Concrete slab must be placed before wall is backfilled
- 6) Maximum surcharge 100 PSF

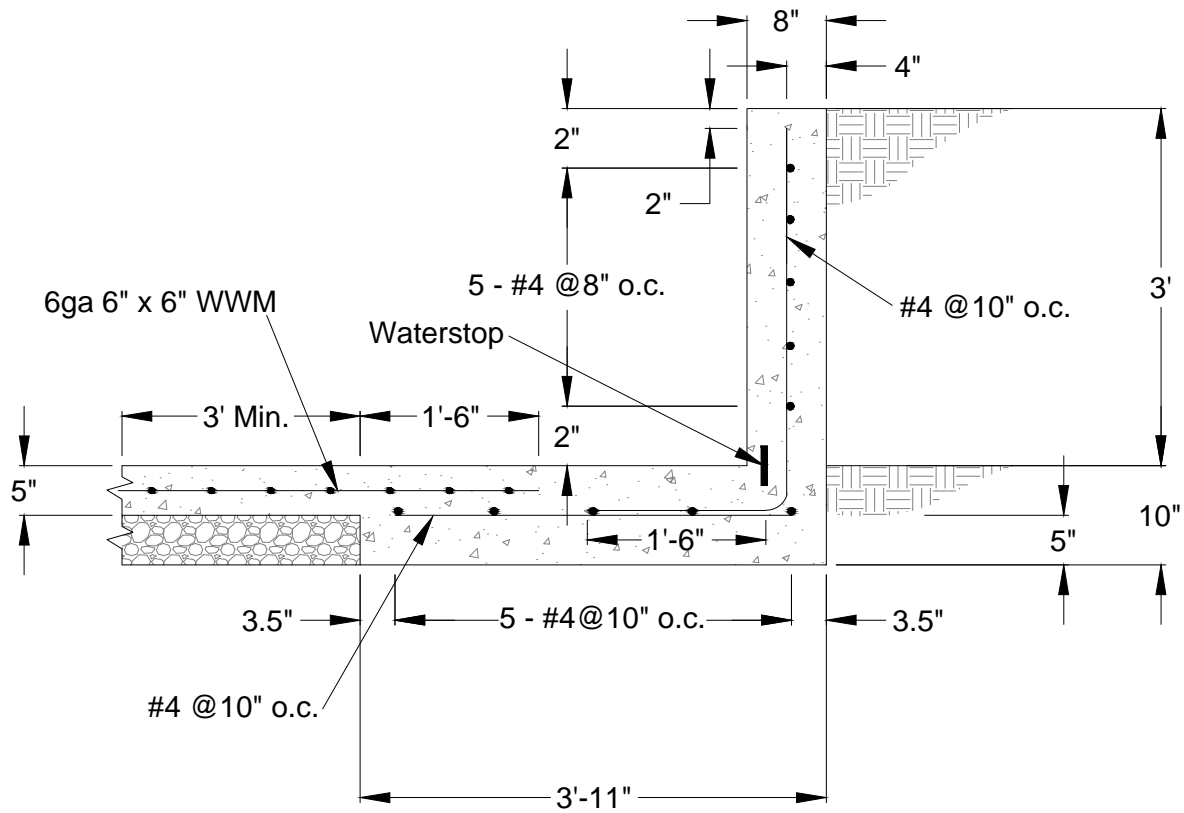

3' RETAINING WALL

NTS

Notes:

- 1) 4000 psi concrete
- 2) Grade 60 steel
- 3) Maximum backfill top of wall (3')
- 4) Minimum backfill to floor
- 5) Concrete slab and footing must be placed at the same time
- 6) Maximum surcharge 100 PSF

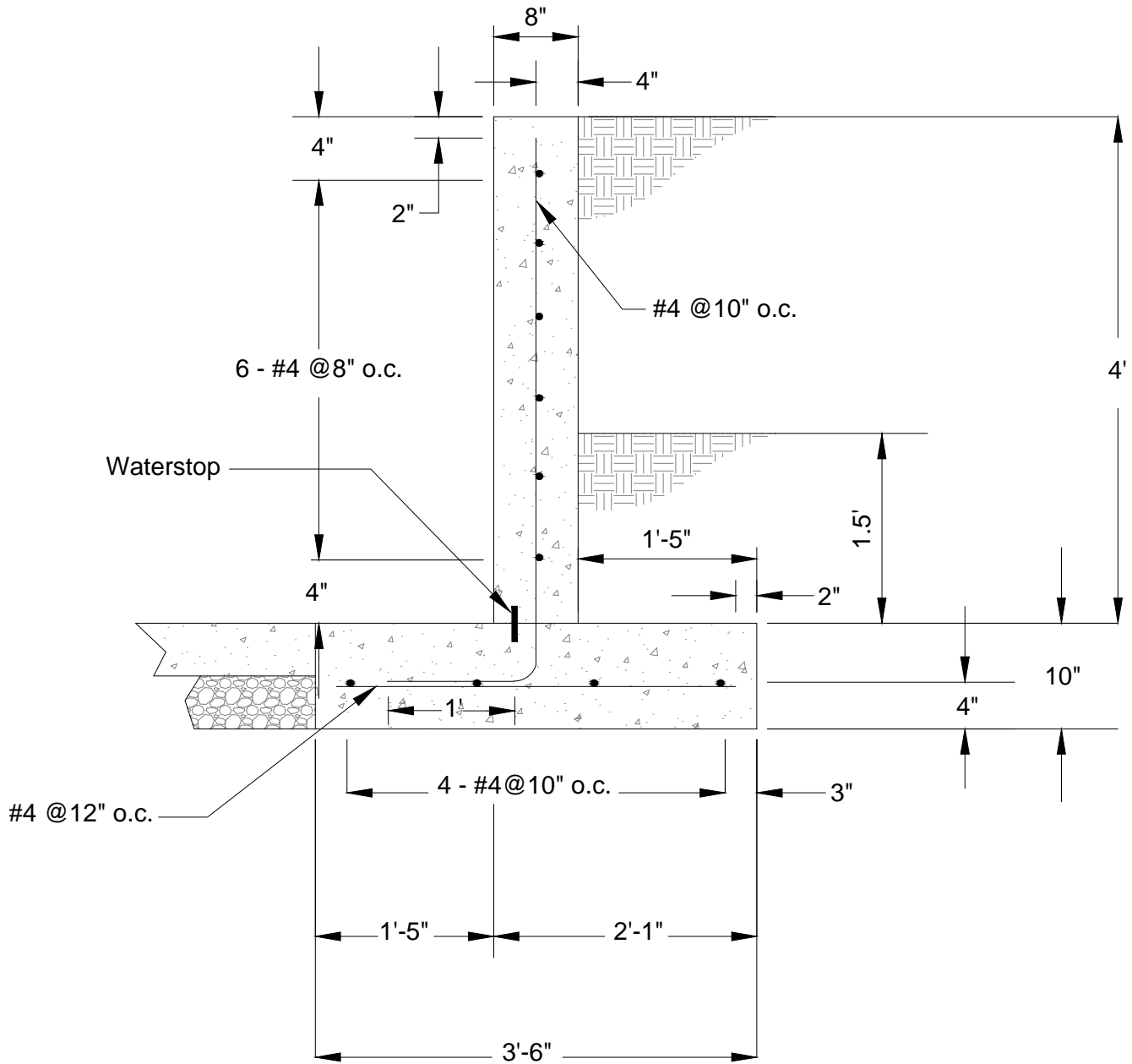

4' RETAINING WALL

NTS

Notes:

- 1) 4000 psi concrete
- 2) Grade 60 steel
- 3) Maximum backfill top of wall (4')
- 4) Minimum backfill 1.5'
- 5) Concrete slab must be placed before wall is backfilled
- 6) Maximum surcharge 100 PSF



UNITED STATES
DEPARTMENT OF
AGRICULTURE

NATURAL RESOURCES CONSERVATION SERVICE
MARYLAND

WALL DESIGNS AND DETAILS FOR WASTE STORAGE

DRAWING NO. CW-4.4.1

ISSUE DATE: 1/2017

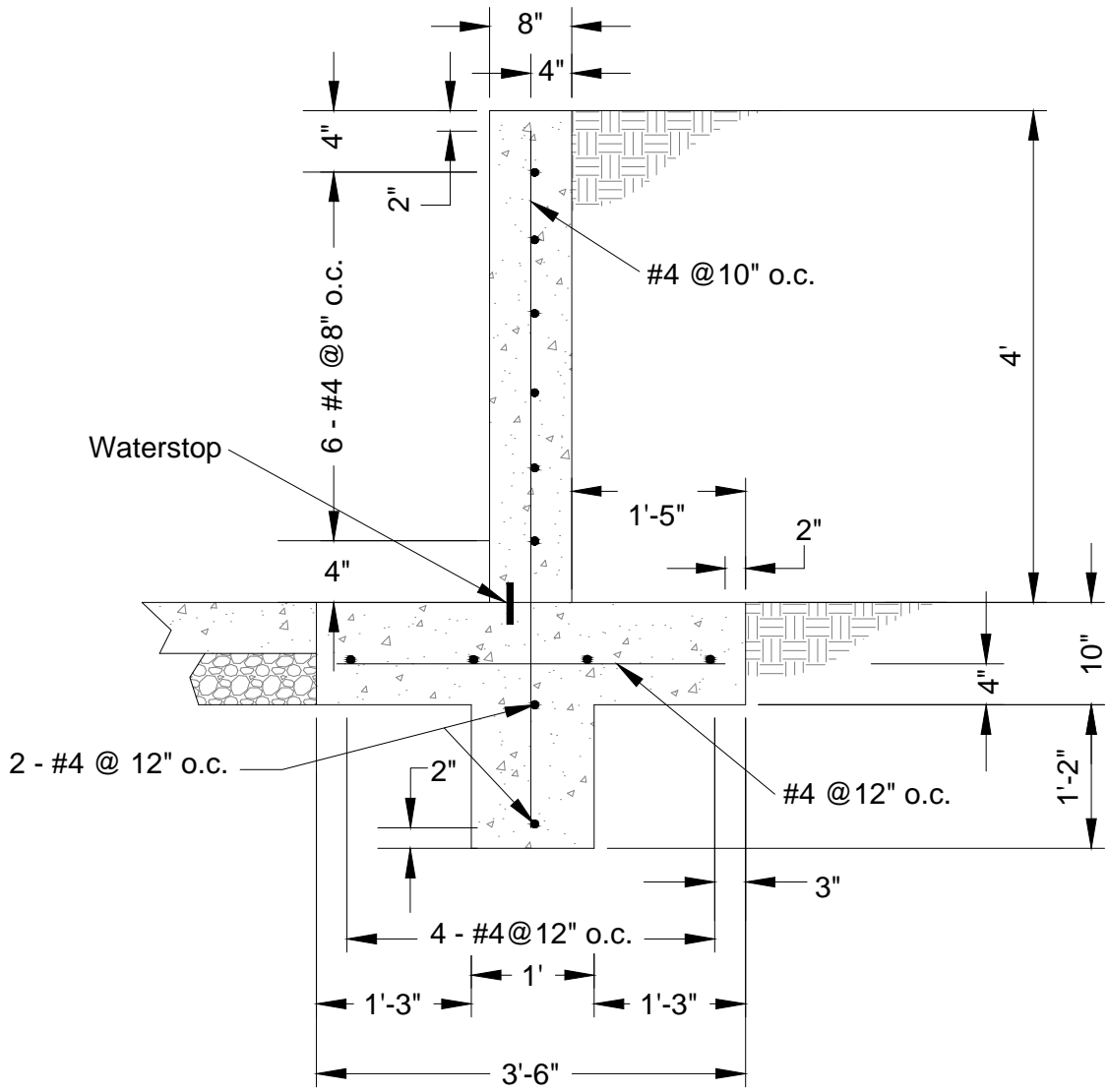

4' RETAINING WALL

NTS

- Notes:
- 1) 4000 psi concrete
 - 2) Grade 60 steel
 - 3) Maximum backfill top of wall (4')
 - 4) Minimum backfill to top of floor
 - 5) Concrete slab must be placed before wall is backfilled
 - 6) Maximum surcharge 100 PSF

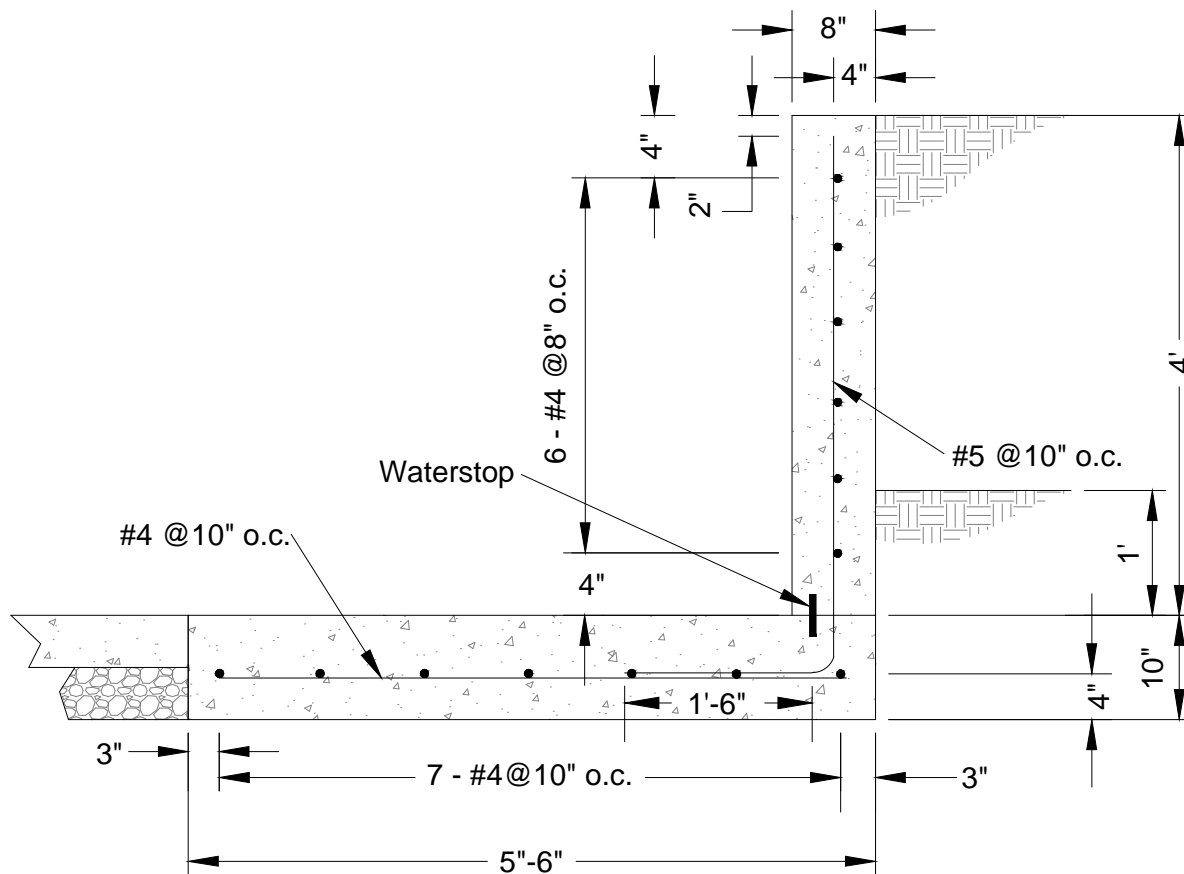

4' RETAINING WALL

NTS

Notes:

- 1) 4000 psi concrete
- 2) Grade 60 steel
- 3) Maximum backfill top of wall (4')
- 4) Minimum backfill 1'
- 5) Concrete slab must be placed before wall is backfilled
- 6) Maximum surcharge 100 PSF

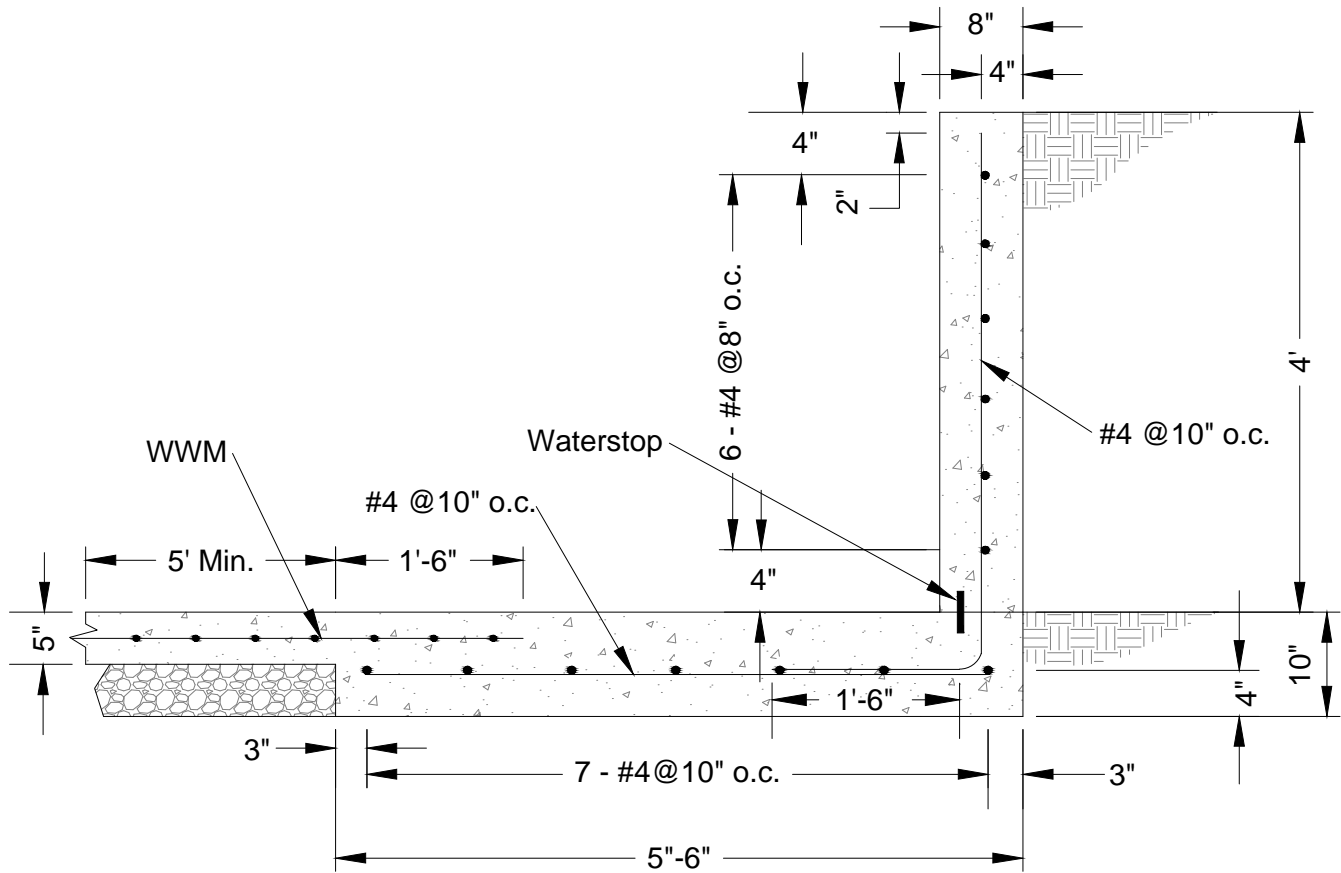

4' RETAINING WALL

NTS

Notes:

- 1) 4000 psi concrete
- 2) Grade 60 steel
- 3) Maximum backfill top of wall (4')
- 4) Minimum backfill top of floor
- 5) Concrete slab and footing must be placed at the same time
- 6) Maximum surcharge 100 PSF

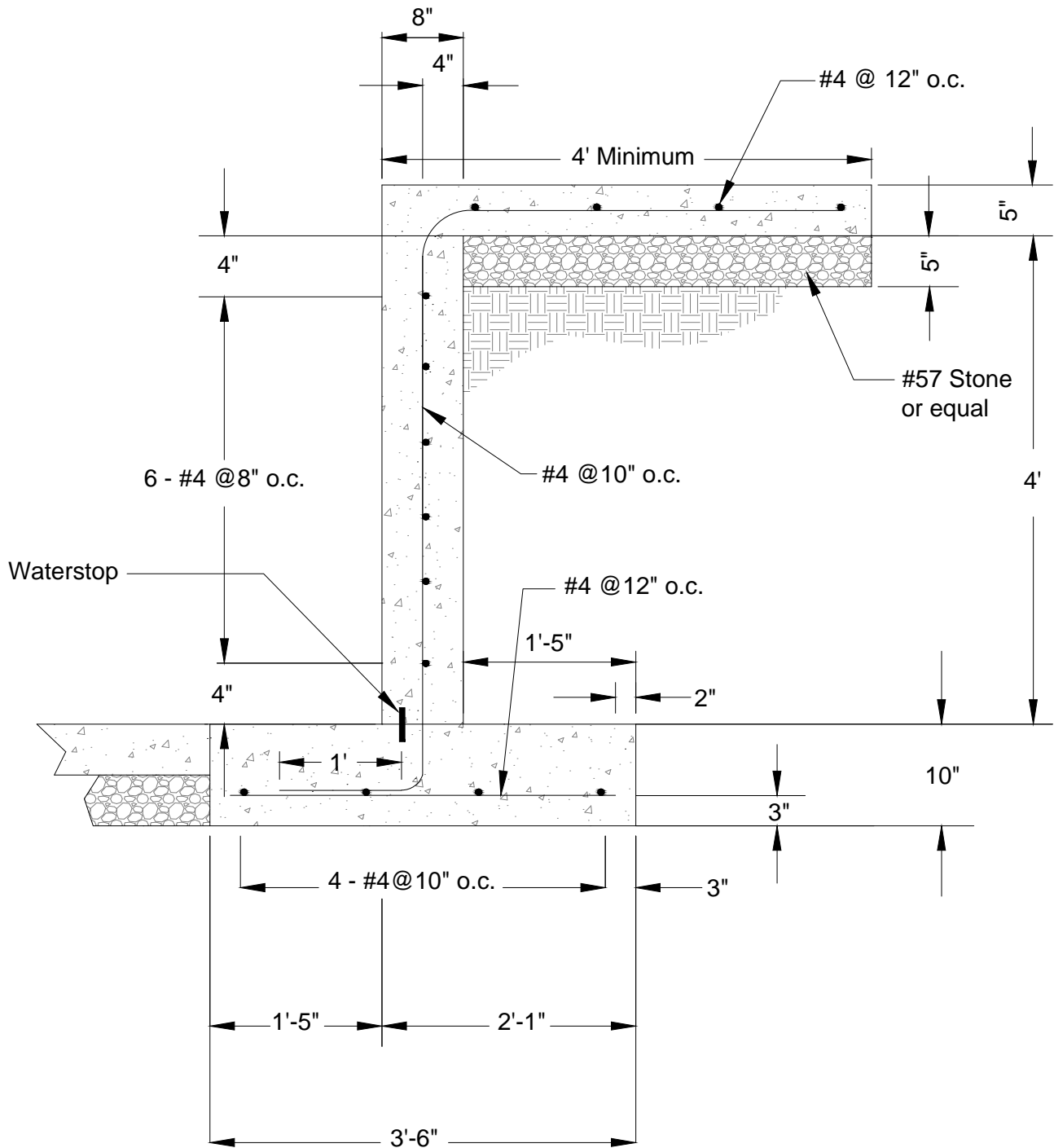

4' RETAINING WALL

NTS

Notes:

- 1) 4000 psi concrete
- 2) Grade 60 steel
- 3) Backfill up to top of wall (4')
- 4) Concrete slab must be placed before wall is backfilled
- 5) Maximum surcharge 250 PSF

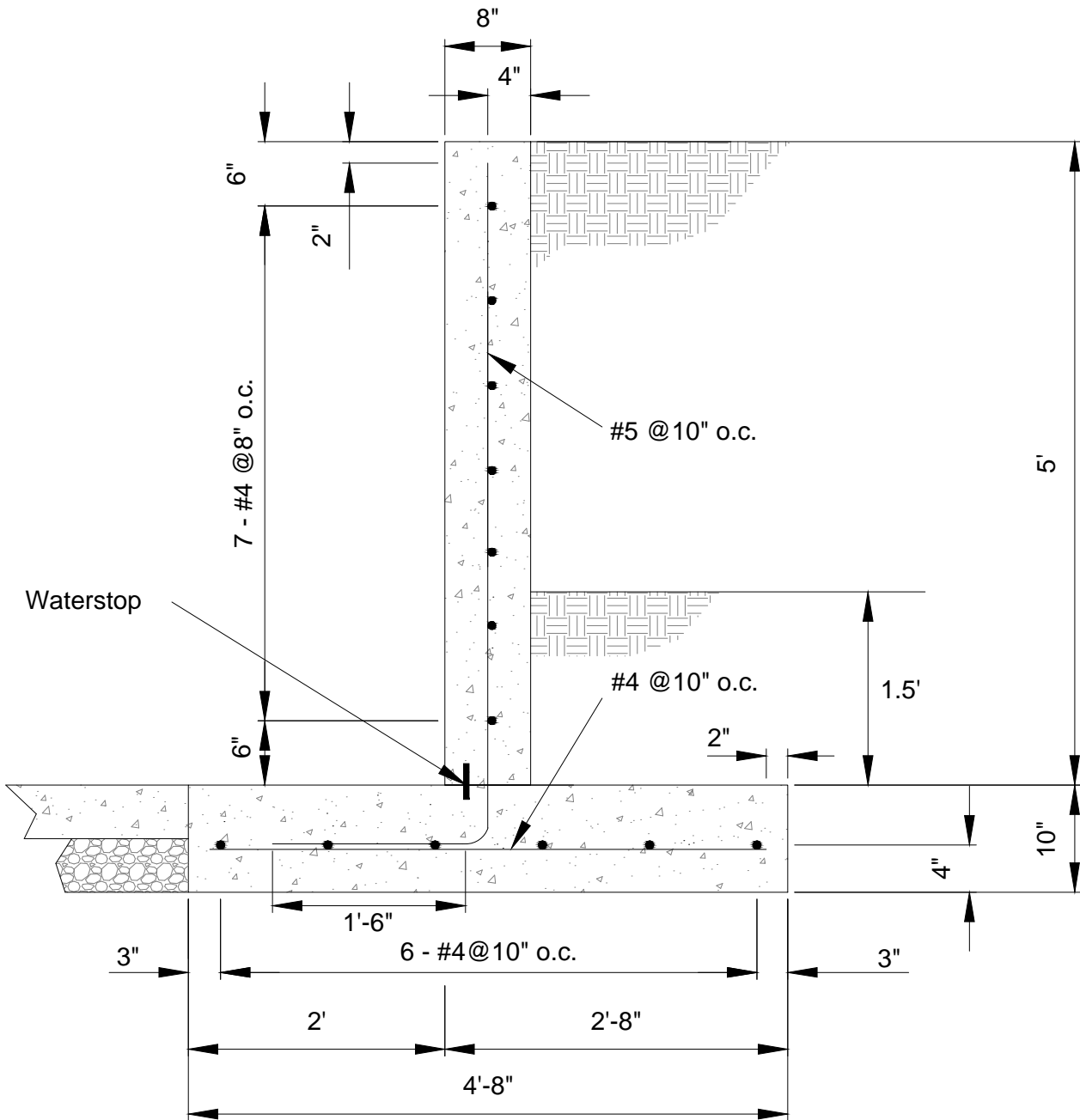

5' RETAINING WALL

NTS

Notes:

- 1) 4000 psi concrete
- 2) Grade 60 steel
- 3) Maximum backfill top of wall (5')
- 4) Minimum backfill 1.5'
- 5) Concrete slab must be placed before wall is backfilled
- 6) Maximum surcharge 100 PSF



NATURAL RESOURCES CONSERVATION SERVICE
MARYLAND

WALL DESIGNS AND DETAILS FOR WASTE STORAGE

DRAWING NO. CW-5.5.1

ISSUE DATE: 1/2017

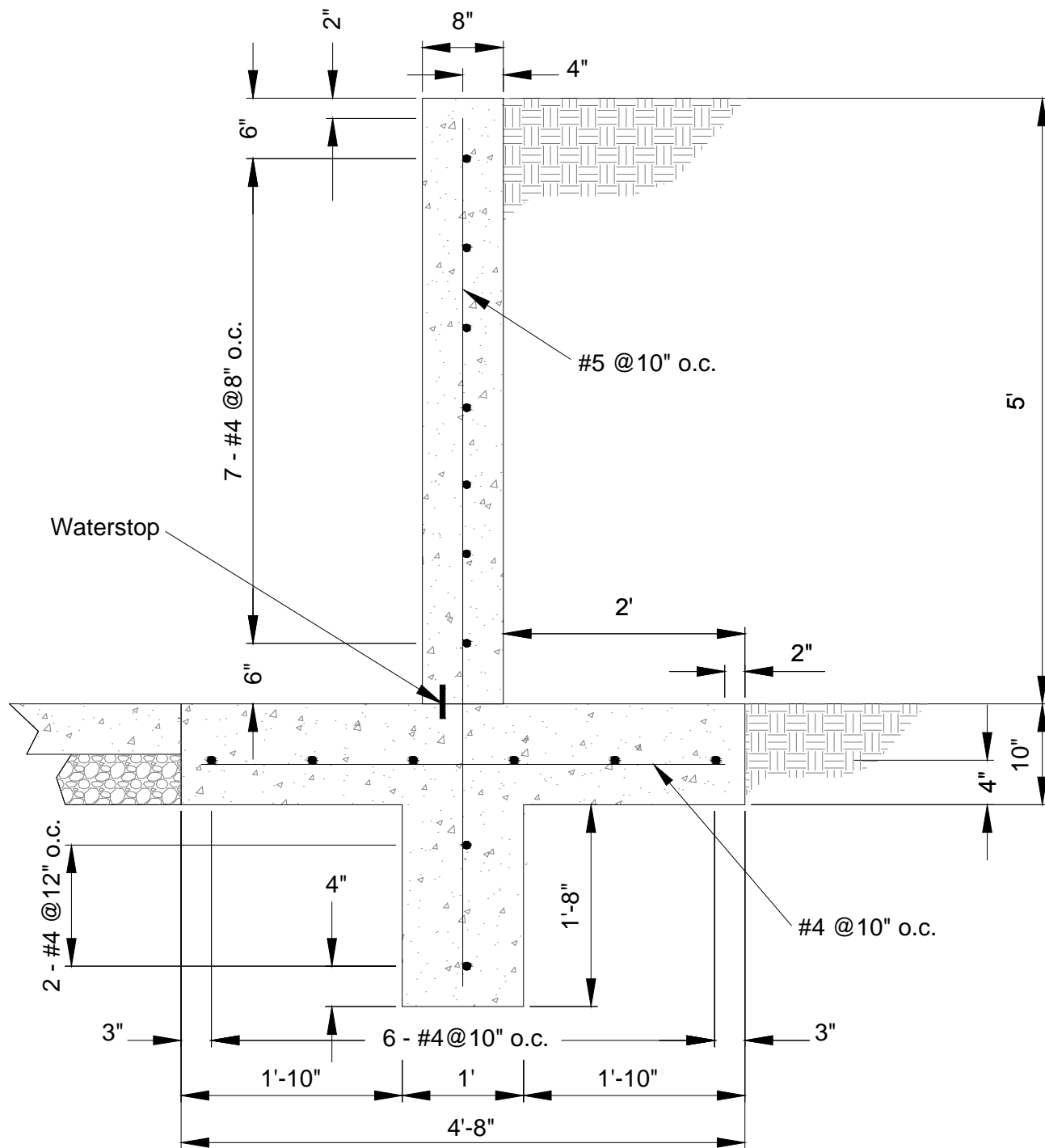

5' RETAINING WALL

NTS

Notes:

- 1) 4000 psi concrete
- 2) Grade 60 steel
- 3) Maximum backfill top of wall (5')
- 4) Minimum backfill to floor
- 5) Concrete slab must be placed before wall is backfilled
- 6) Maximum surcharge 100 PSF

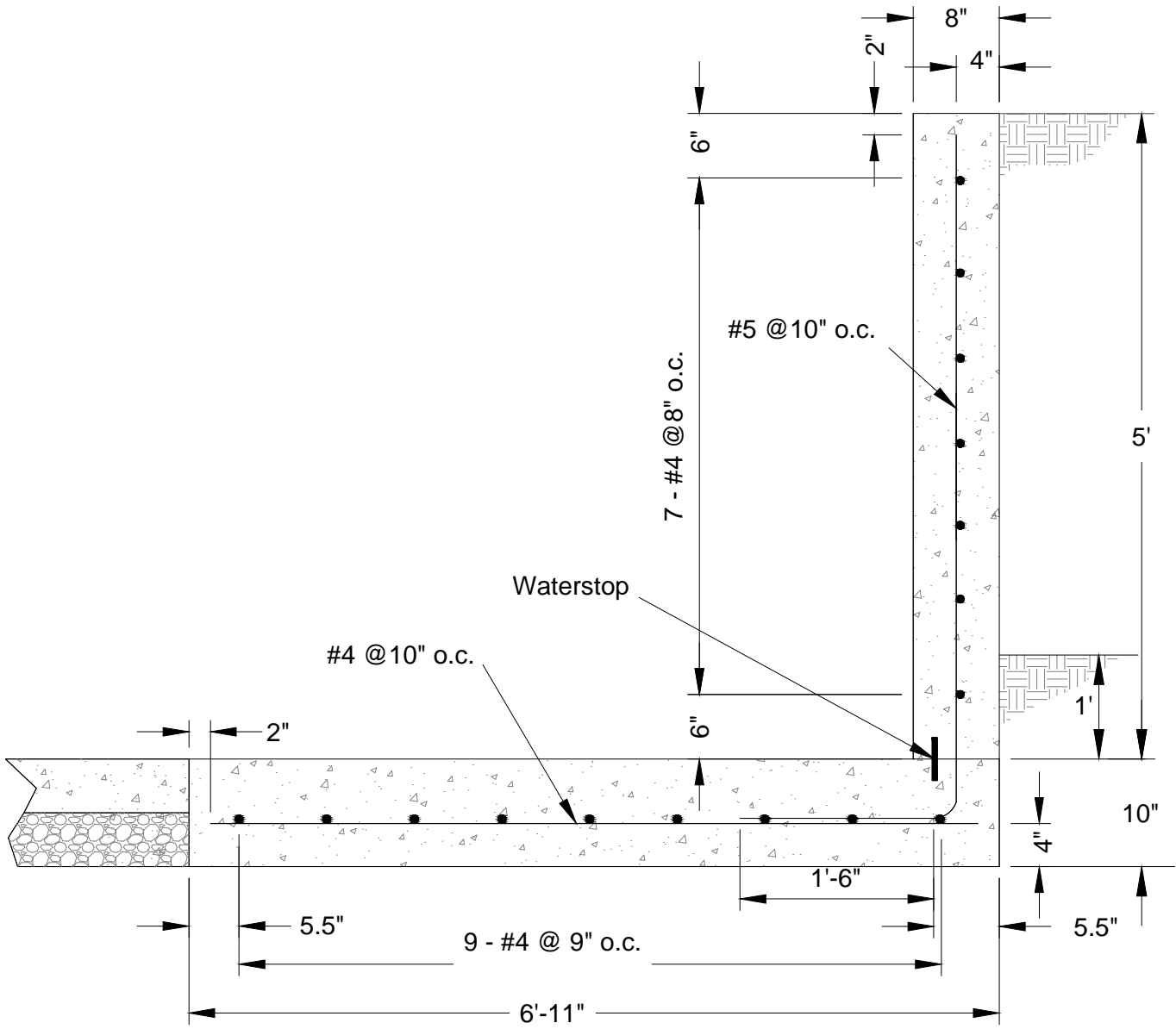

5' RETAINING WALL

NTS

Notes:

- 1) 4000 psi concrete
- 2) Grade 60 steel
- 3) Maximum backfill top of wall (5')
- 4) Minimum backfill 1'
- 5) Concrete slab must be placed before wall is backfilled
- 6) Maximum surcharge 100 PSF

<p style="font-size: 8px;">UNITED STATES DEPARTMENT OF AGRICULTURE</p> <p style="font-size: 8px;">NATURAL RESOURCES CONSERVATION SERVICE MARYLAND</p>	WALL DESIGNS AND DETAILS FOR WASTE STORAGE	DRAWING NO. CW-5.5.1L
		ISSUE DATE: 1/2017

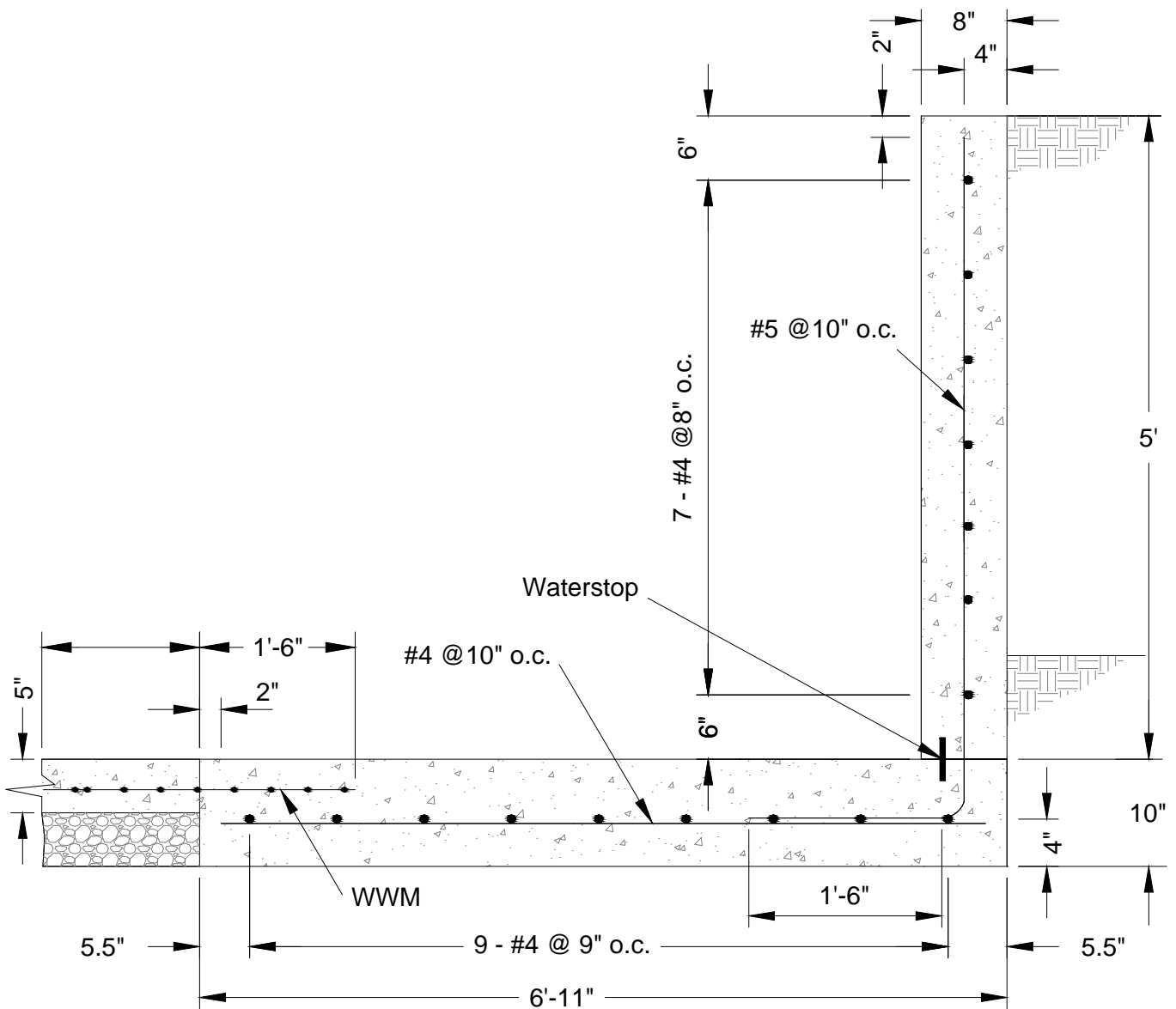

5' RETAINING WALL

NTS

Notes:

- 1) 4000 psi concrete
- 2) Grade 60 steel
- 3) Maximum backfill top of wall (5')
- 4) Minimum backfill top of floor
- 5) Concrete slab and footing must be placed at the same time
- 6) Maximum surcharge 100 PSF

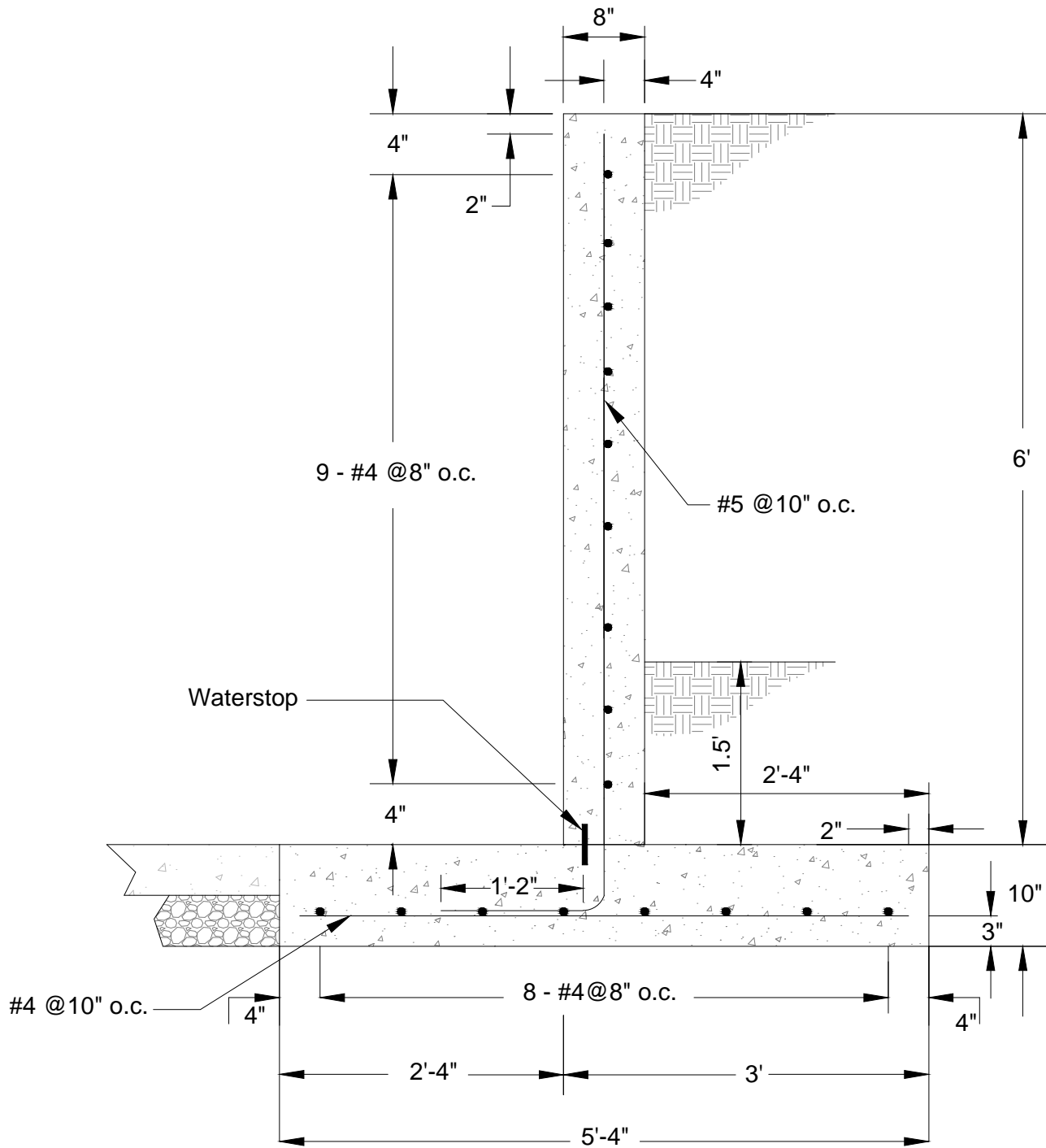

6' RETAINING WALL

NTS

Notes:

- 1) 4000 psi concrete
- 2) Grade 60 steel
- 3) Maximum backfill top of wall (6')
- 4) Minimum backfill 1.5'
- 5) Concrete slab must be placed before wall is backfilled
- 6) Maximum surcharge 100 PSF

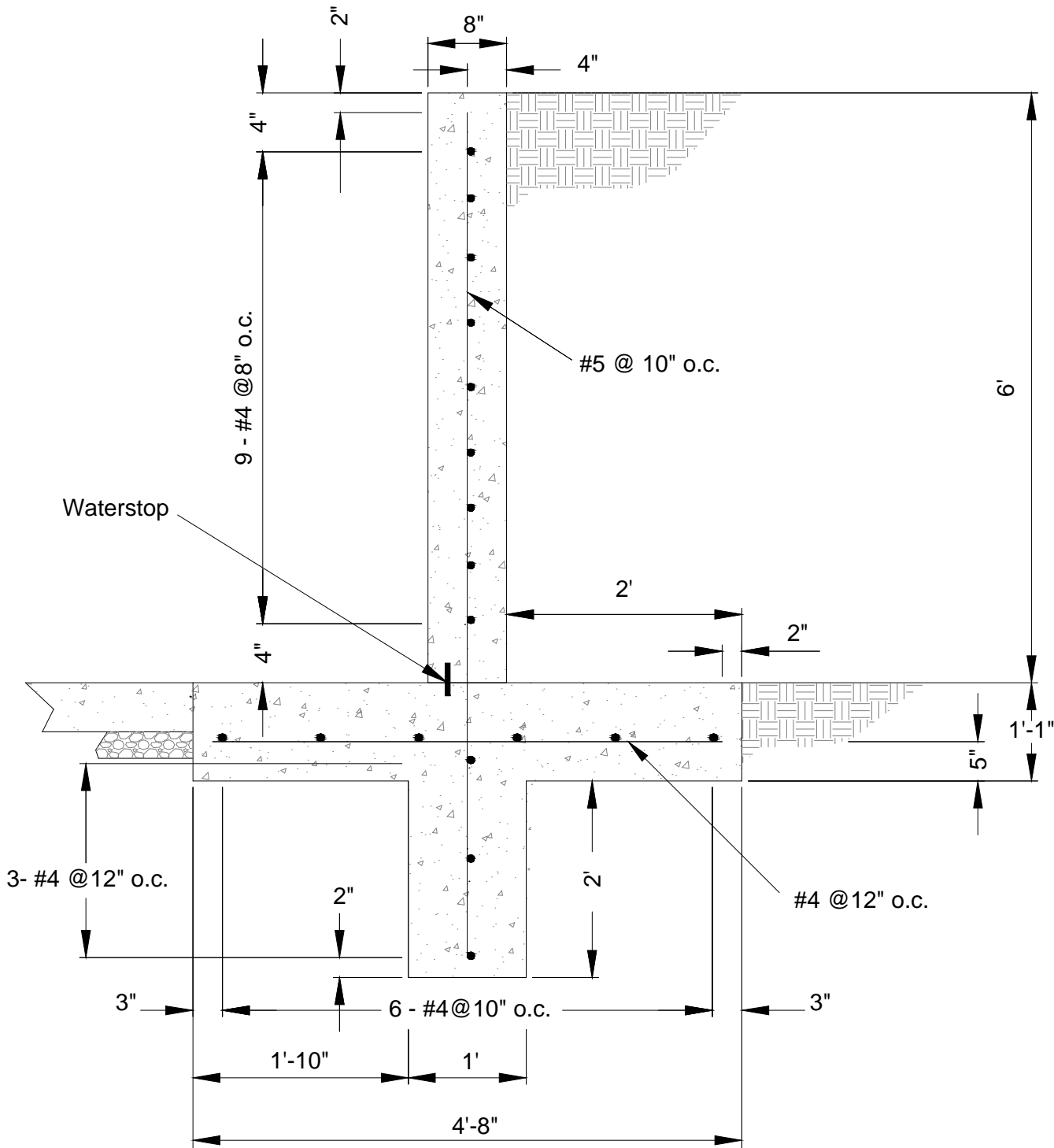

6' RETAINING WALL

NTS

Notes:

- 1) 4000 psi concrete
- 2) Grade 60 steel
- 3) Maximum backfill top of wall (6')
- 4) Minimum backfill top of floor
- 5) Concrete slab must be placed before wall is backfilled
- 6) Maximum surcharge 100 PSF



WALL DESIGNS AND DETAILS
FOR WASTE STORAGE

DRAWING NO. CW-6.6.0

ISSUE DATE: 1/2017

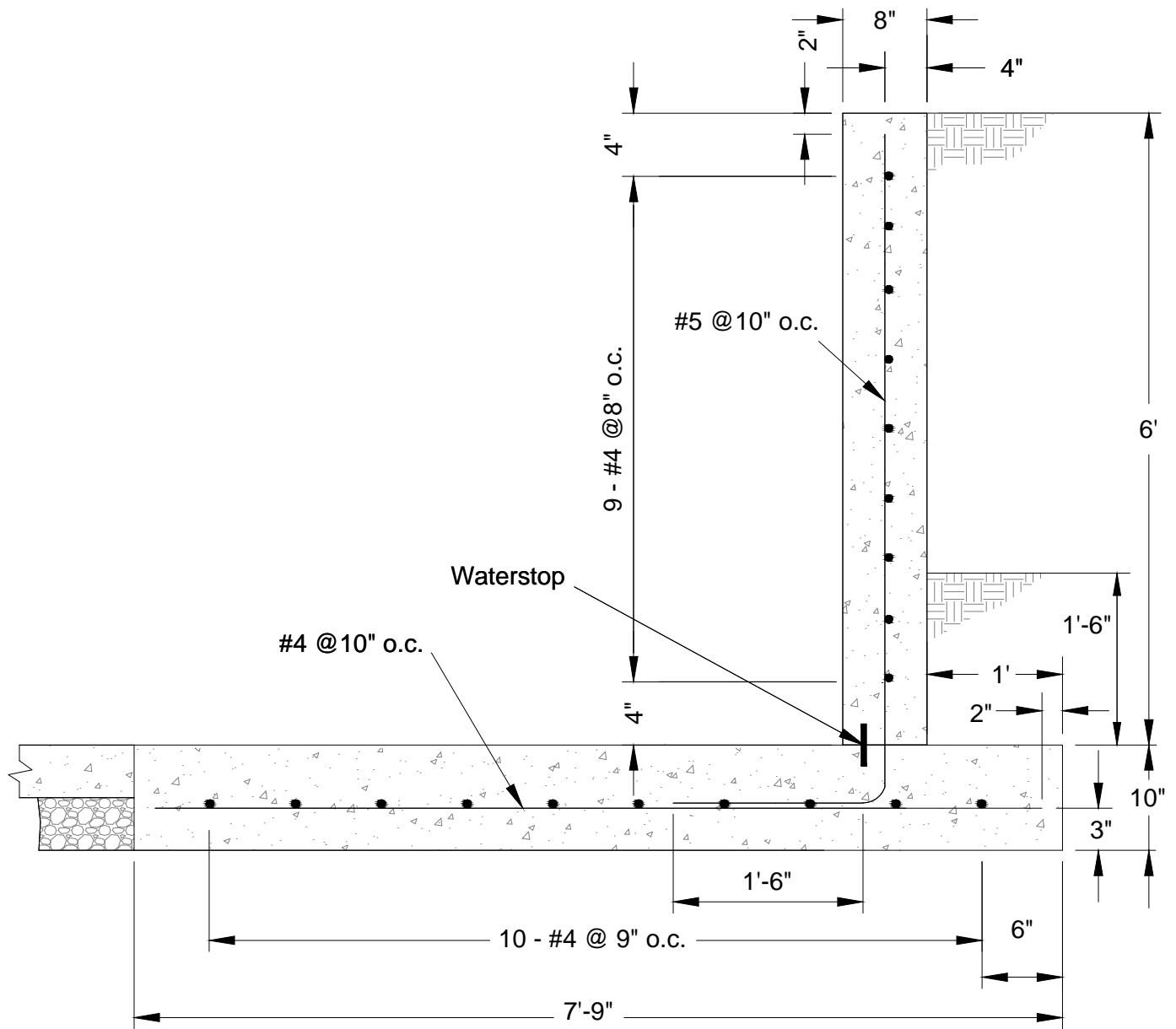

6' RETAINING WALL

NTS

Notes:

- 1) 4000 psi concrete
- 2) Grade 60 steel
- 3) Maximum backfill top of wall (6')
- 4) Minimum backfill 1.5'
- 5) Concrete slab must be placed before wall is backfilled
- 6) Maximum surcharge 100 PSF

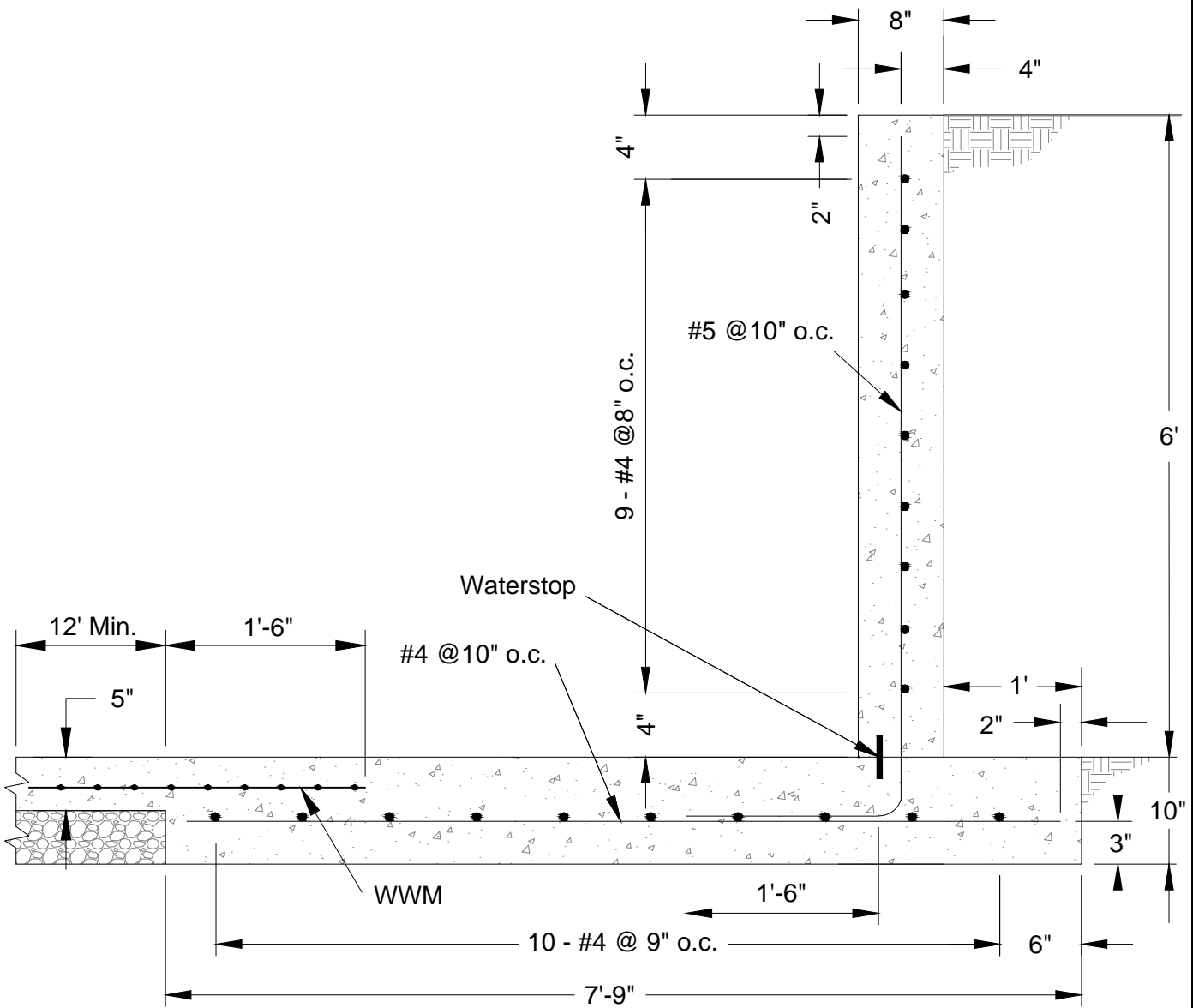

6' RETAINING WALL

NTS

Notes:

- 1) 4000 psi concrete
- 2) Grade 60 steel
- 3) Maximum backfill top of wall (6')
- 4) Minimum backfill top of floor
- 5) Concrete slab must be placed before wall is backfilled
- 6) Maximum surcharge 100 PSF



WALL DESIGNS AND DETAILS
FOR WASTE STORAGE

DRAWING NO. CW-6.6.0L

ISSUE DATE: 1/2017

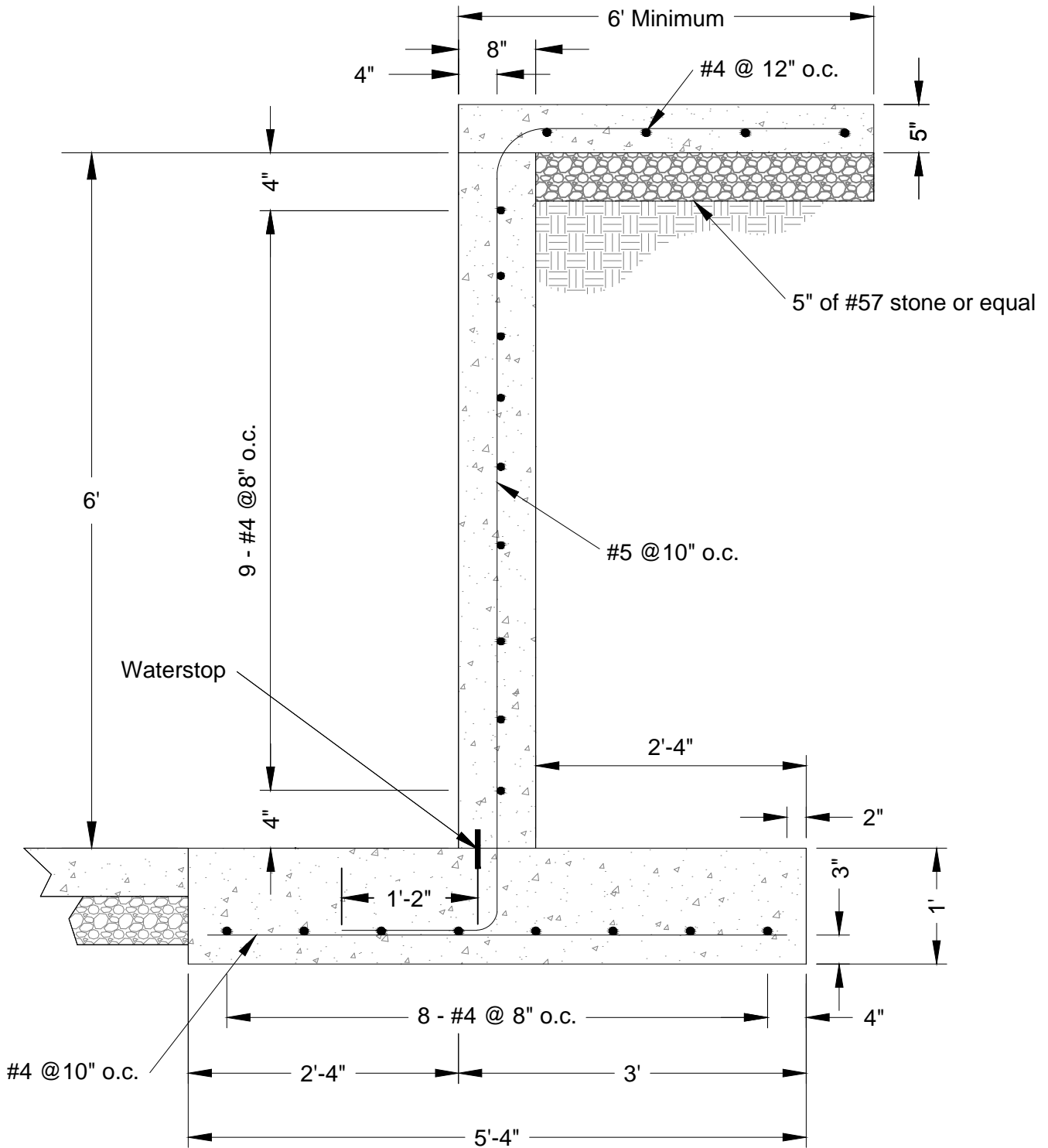

6' RETAINING WALL

NTS

Notes:

- 1) 4000 psi concrete
- 2) Grade 60 steel
- 3) Backfill to top of wall (6')
- 4) Toe concrete slab must be placed before wall is backfilled
- 5) Maximum surcharge 250 PSF



UNITED STATES
DEPARTMENT OF
AGRICULTURE

NATURAL RESOURCES CONSERVATION SERVICE
MARYLAND

WALL DESIGNS AND DETAILS
FOR WASTE STORAGE

DRAWING NO. CW-6.6.6R

ISSUE DATE: 1/2017

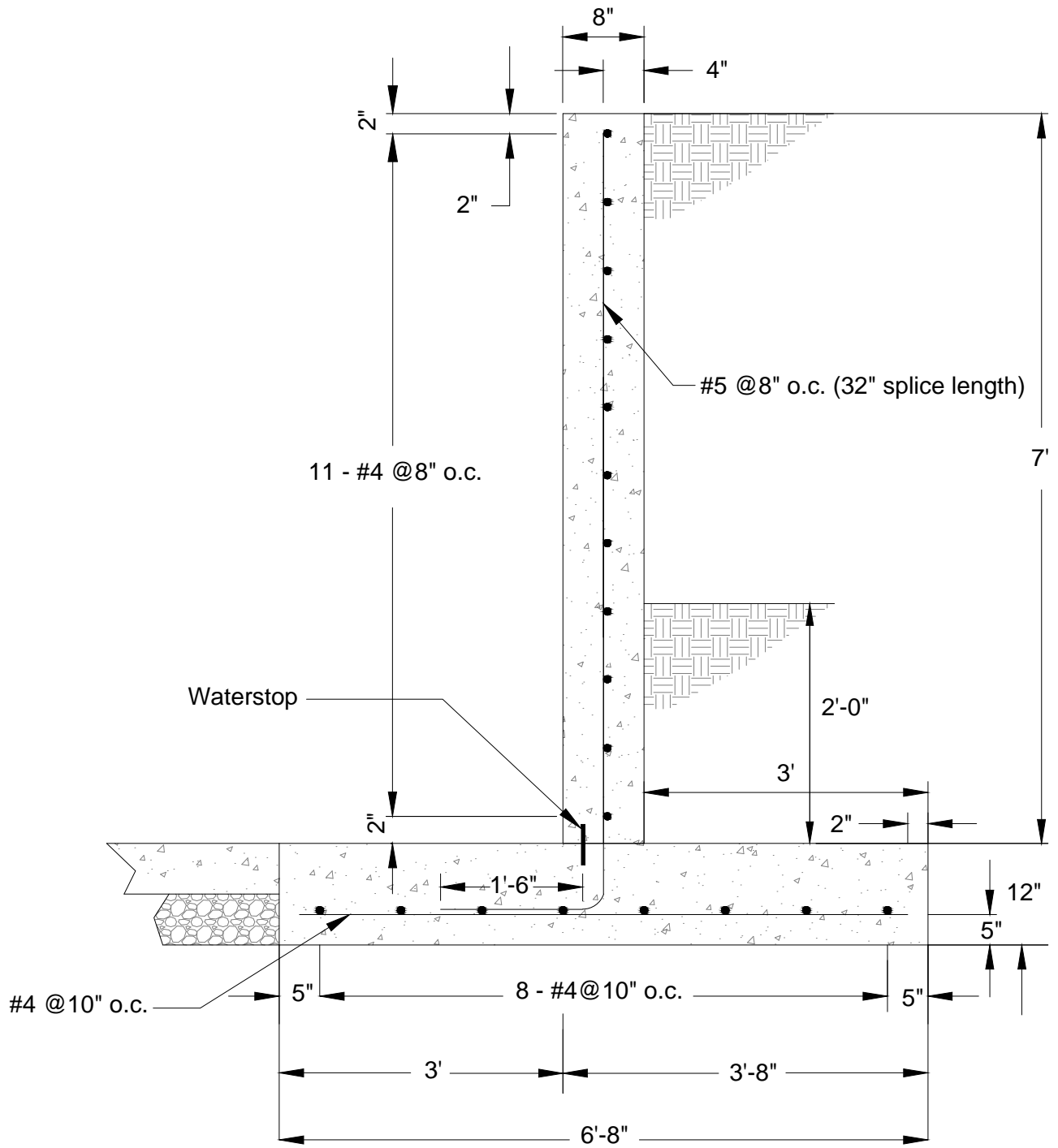

7' RETAINING WALL

NTS

Notes:

- 1) 4000 psi concrete
- 2) Grade 60 steel
- 3) Maximum backfill top of wall (7')
- 4) Minimum backfill 2'
- 5) Concrete slab must be placed before wall is backfilled
- 6) Maximum surcharge 100 PSF



WALL DESIGNS AND DETAILS FOR WASTE STORAGE

DRAWING NO. CW-7.7.2

ISSUE DATE: 1/2017

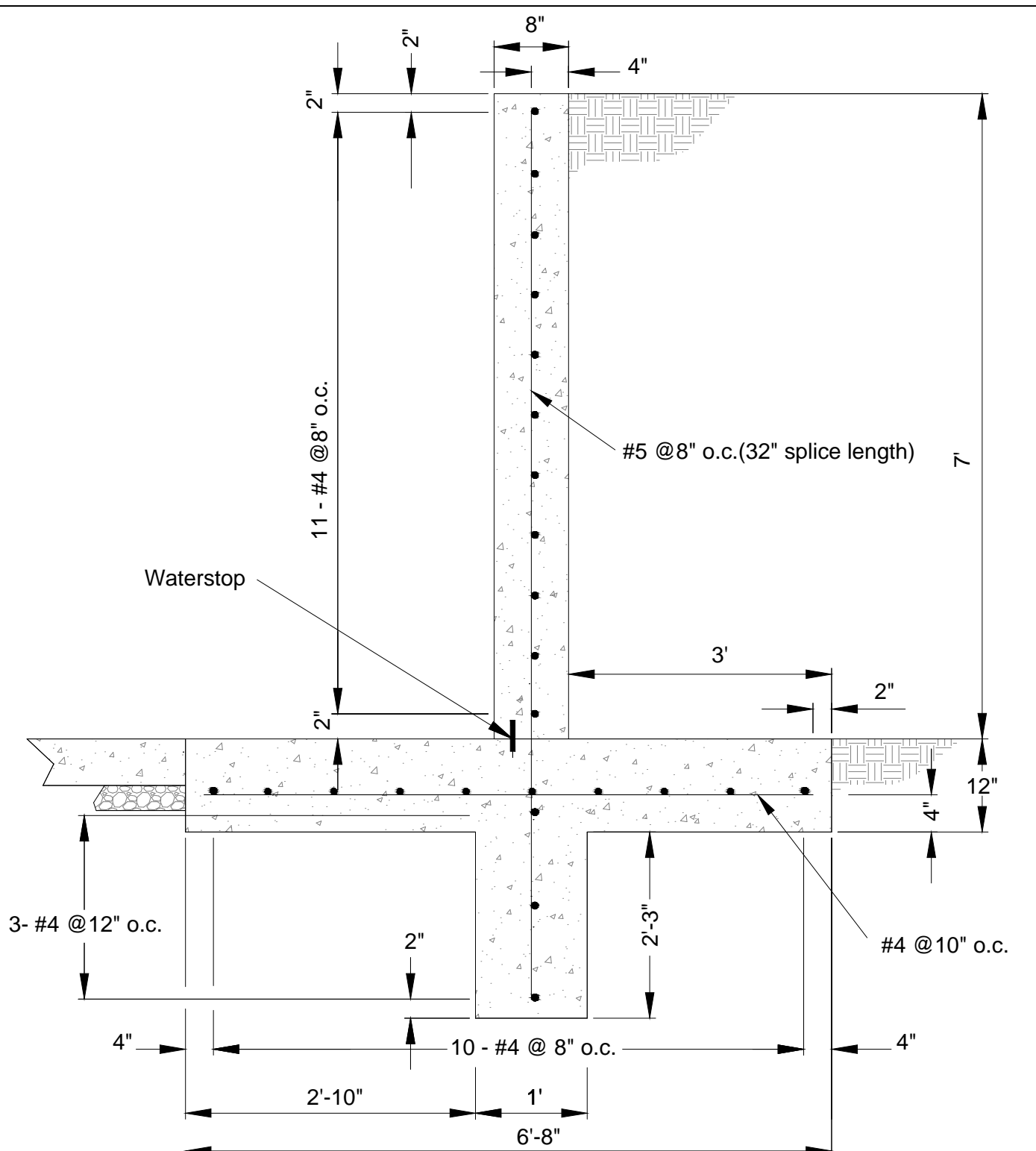

7' RETAINING WALL

NTS

- Notes:
- 1) 4000 psi concrete
 - 2) Grade 60 steel
 - 3) Maximum backfill top of wall (7')
 - 4) Minimum backfill to floor
 - 5) Concrete slab must be placed before wall is backfilled
 - 6) Maximum surcharge 100 PSF

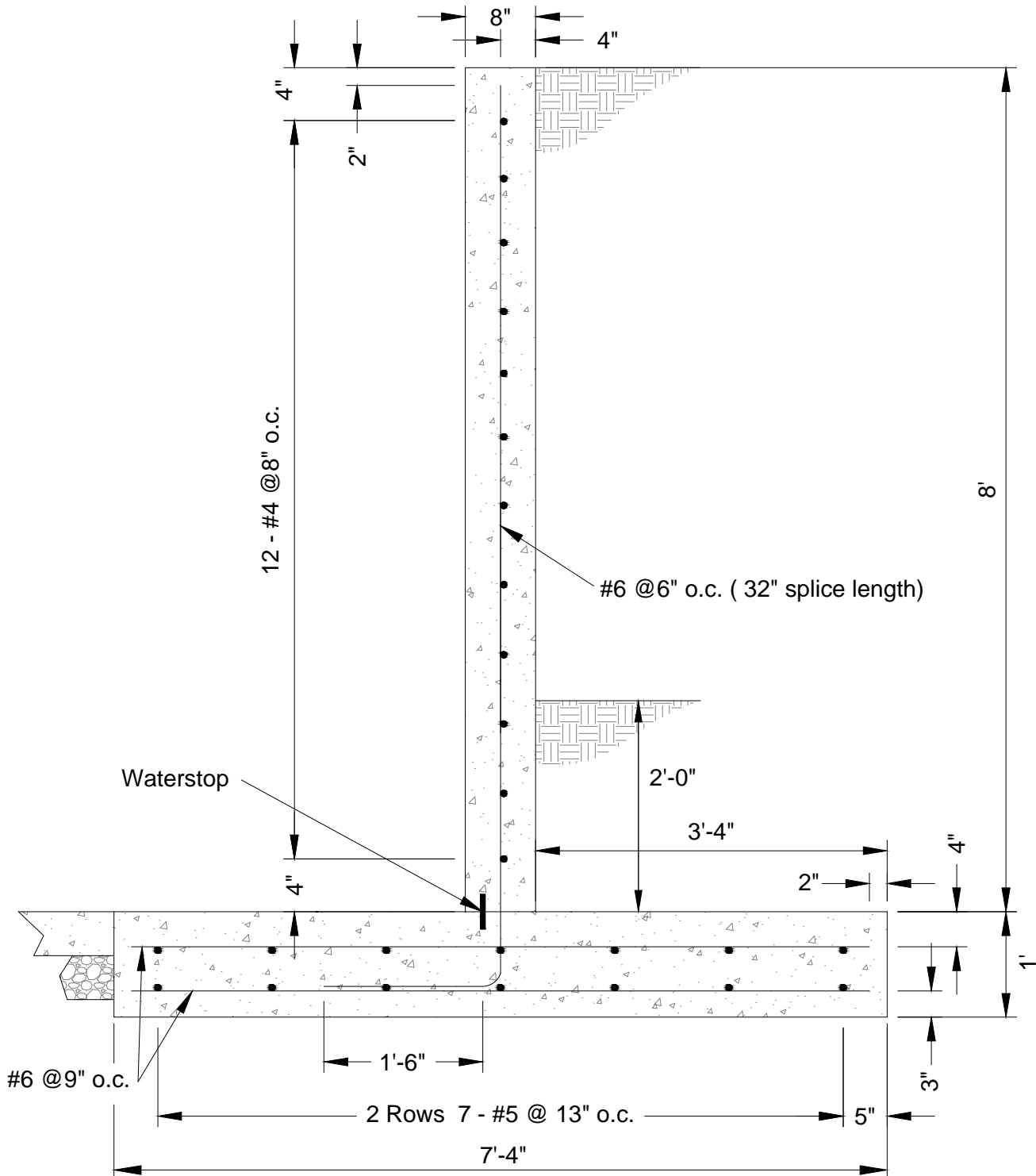

8' RETAINING WALL

NTS

Notes:

- 1) 4000 psi concrete
- 2) Grade 60 steel
- 3) Maximum backfill top of wall (8')
- 4) Minimum backfill 2'
- 5) Concrete slab must be placed before wall is backfilled
- 6) Maximum surcharge 100 PSF



WALL DESIGNS AND DETAILS
FOR WASTE STORAGE

DRAWING NO. CW-8.8.2

ISSUE DATE: 1/2017

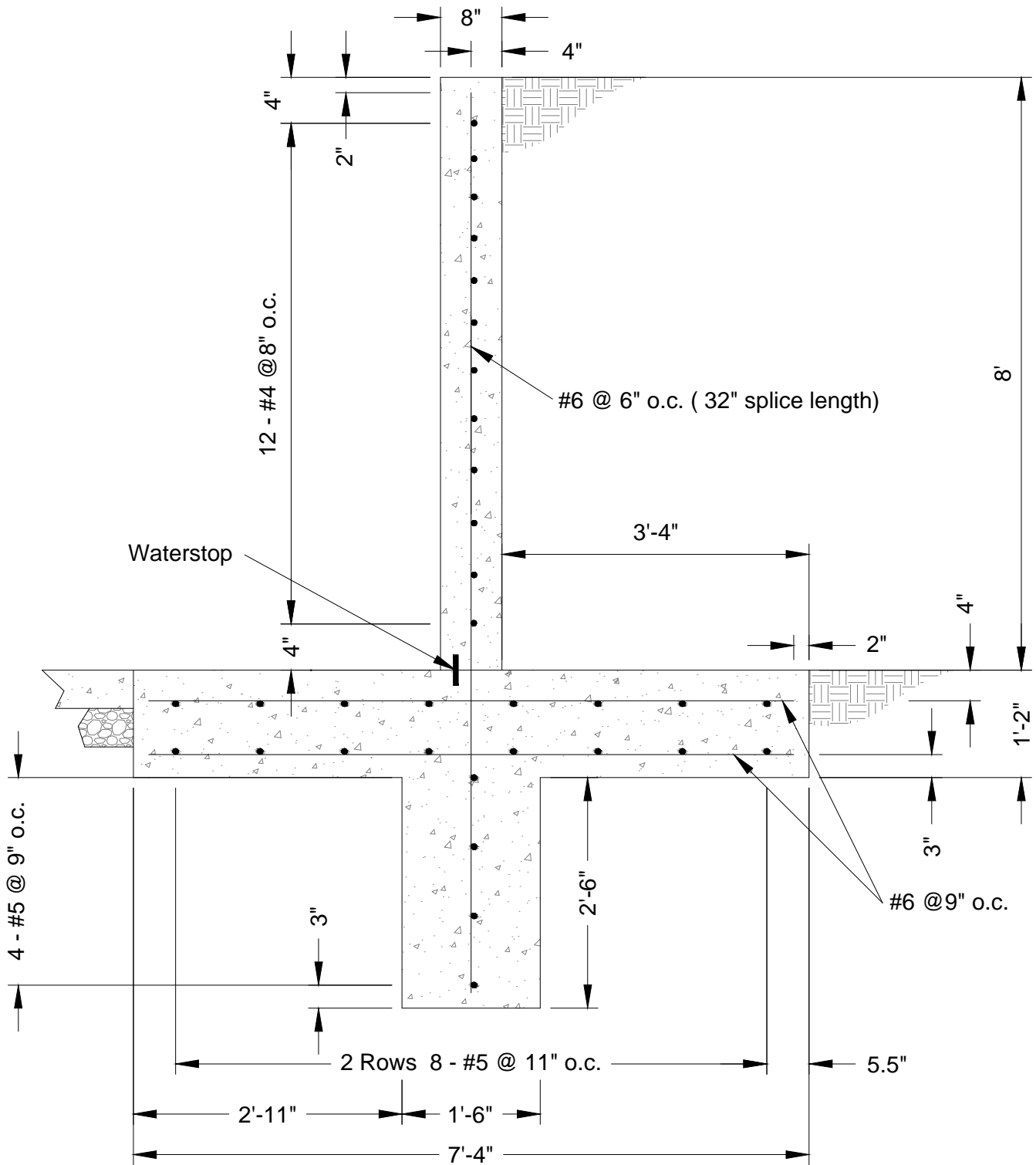

8' RETAINING WALL

NTS

Notes:

- | | |
|--------------------------------------|---|
| 1) 4000 psi concrete | 4) Minimum to floor |
| 2) Grade 60 steel | 5) Concrete slab must be placed before wall is backfilled |
| 3) Maximum backfill top of wall (8') | 6) Maximum surcharge 100 PSF |



WALL DESIGNS AND DETAILS
FOR WASTE STORAGE

DRAWING NO. CW-8.8.0

ISSUE DATE: 1/2017

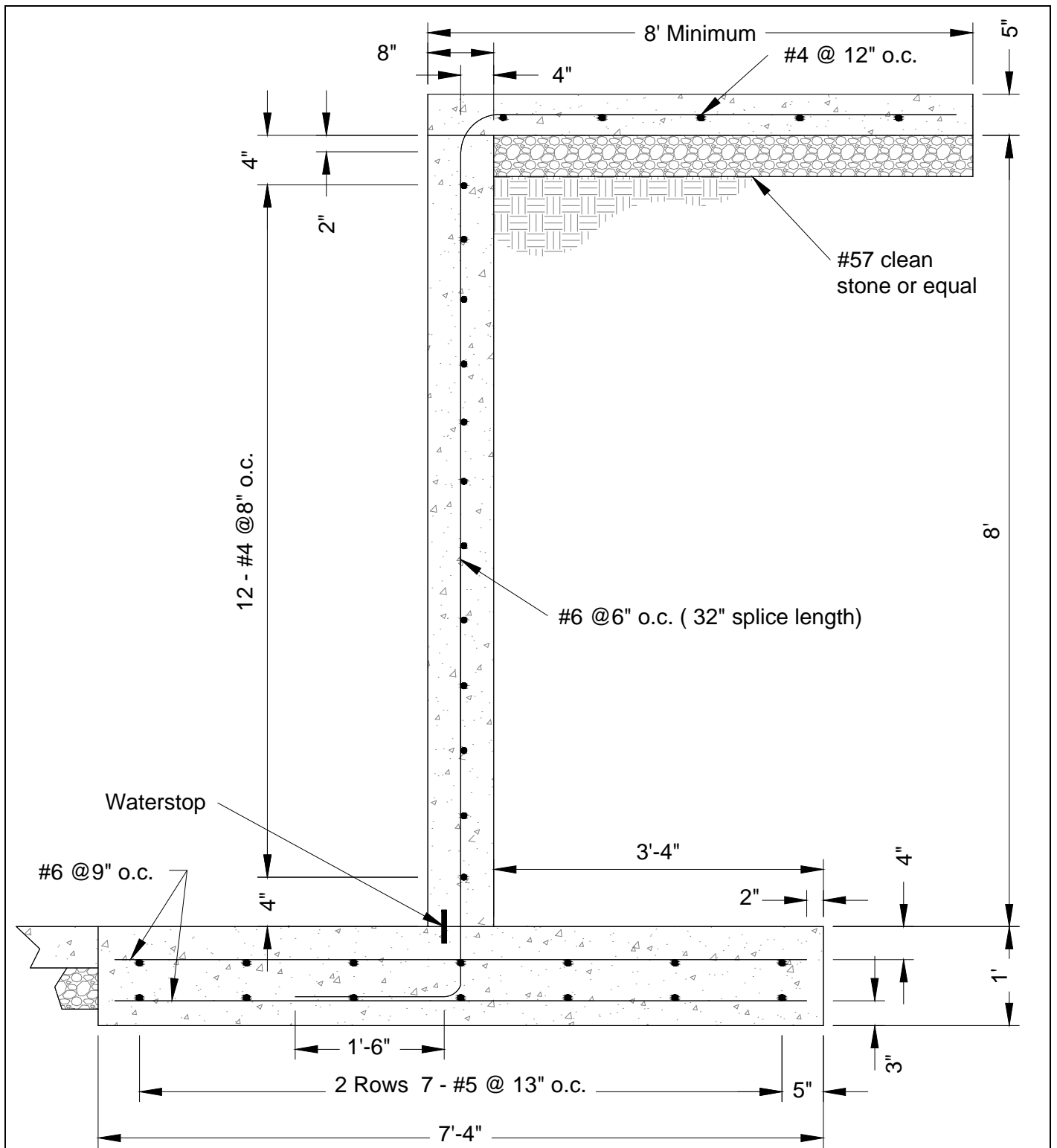

8' RETAINING WALL

NTS

Notes:

- 1) 4000 psi concrete
- 2) Grade 60 steel
- 3) Maximum backfill top of wall (8')
- 5) Concrete slab must be placed before wall is backfilled
- 6) Maximum surcharge 250 PSF

 UNITED STATES DEPARTMENT OF AGRICULTURE NATURAL RESOURCES CONSERVATION SERVICE MARYLAND	WALL DESIGNS AND DETAILS FOR WASTE STORAGE	DRAWING NO. CW-8.8.8R
		ISSUE DATE: 1/2017

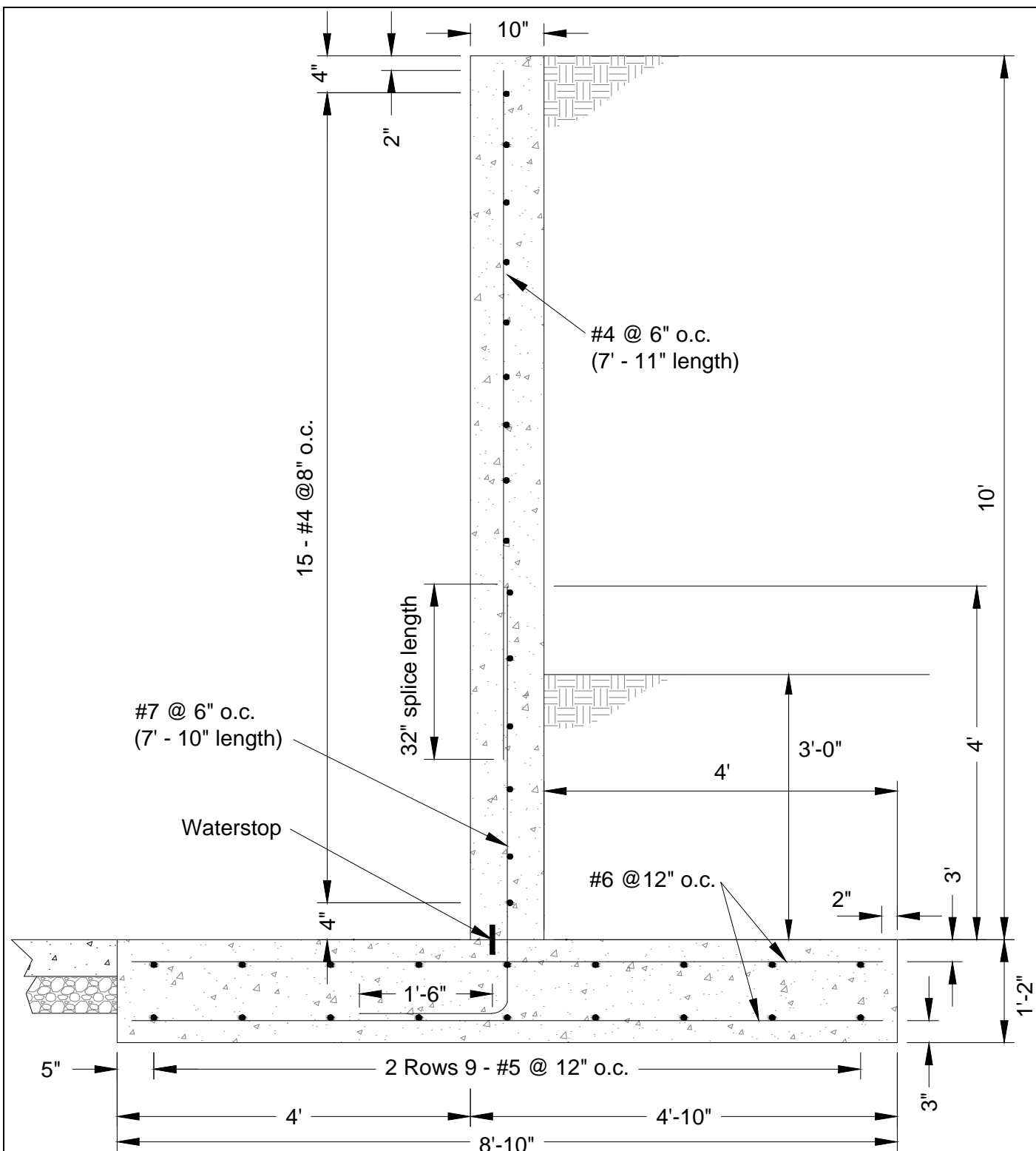

Notes:

- 1) 4000 psi concrete
- 2) Grade 60 steel
- 3) Maximum backfill top of wall (10')
- 4) Minimum backfill 3'
- 5) Concrete slab must be placed before wall is backfilled
- 6) Maximum surcharge 250 PSF

10' RETAINING WALL

NTS



WALL DESIGNS AND DETAILS FOR WASTE STORAGE

DRAWING NO. CW-10.10.3

ISSUE DATE: 1/2017

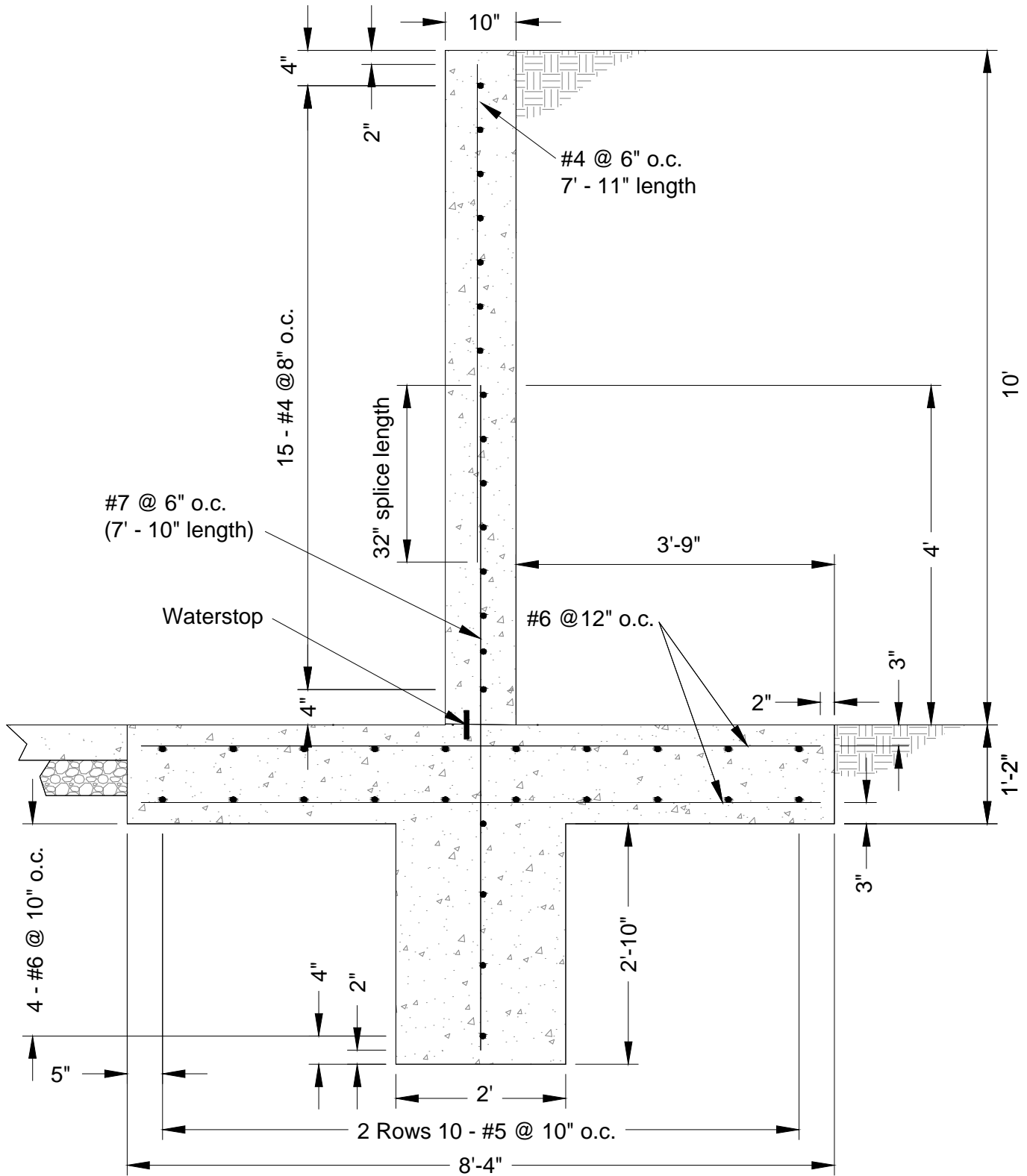

10' RETAINING WALL

Notes:

- 1) 4000 psi concrete
- 2) Grade 60 steel
- 3) Maximum backfill top of wall (10')
- 4) Minimum backfill top of wall
- 5) Concrete slab must be placed before wall is backfilled
- 6) Maximum surcharge 250 PSF

NTS



WALL DESIGNS AND DETAILS
FOR WASTE STORAGE

DRAWING NO. CW-10.10.0

ISSUE DATE: 1/2017

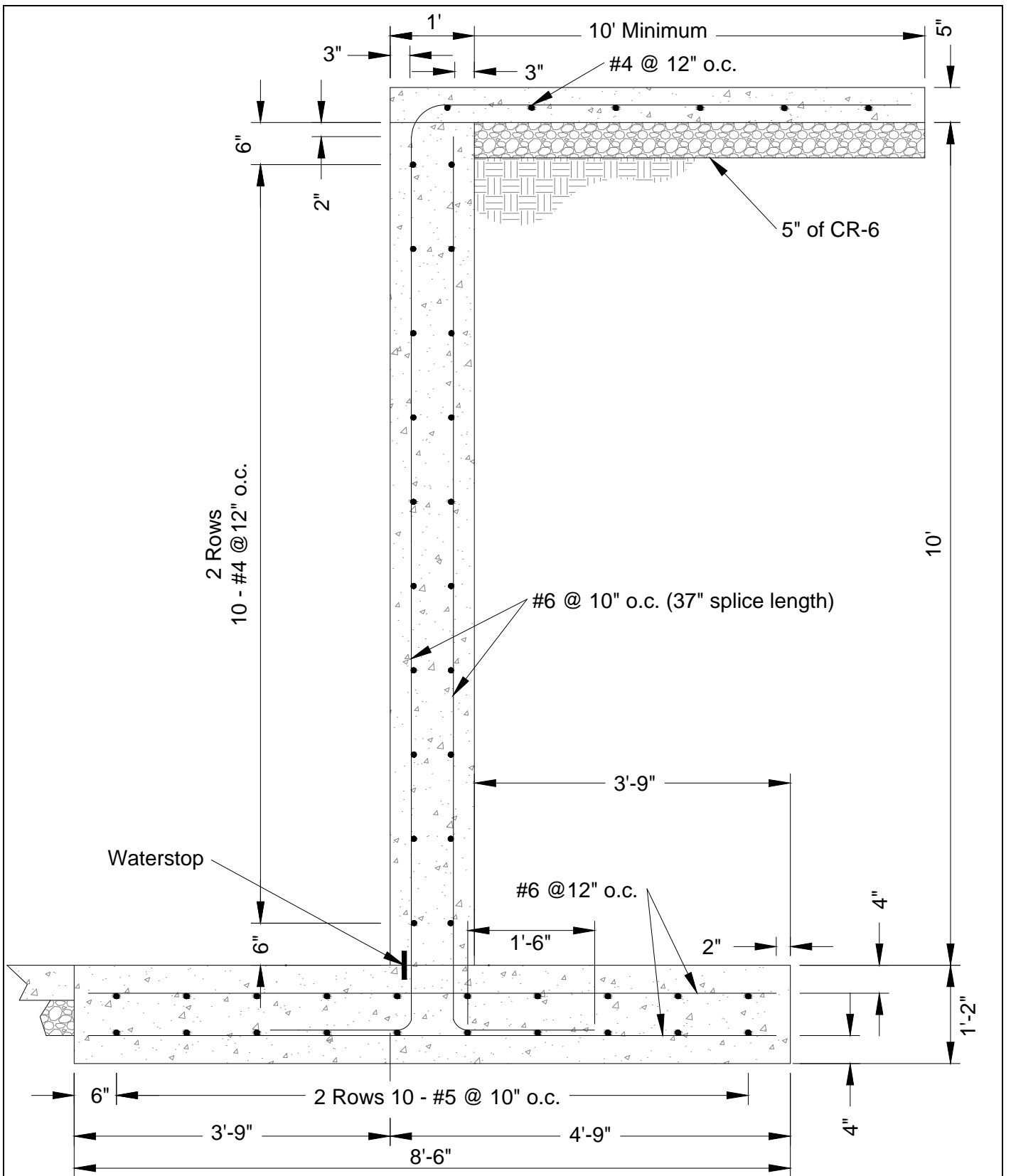

Notes:

- 1) 4000 psi concrete
- 2) Grade 60 steel
- 3) Maximum backfill top of wall (10')
- 4) NTS
- 5) Concrete slab must be placed before wall is backfilled
- 6) Maximum surcharge 250 PSF

10' RETAINING WALL

NTS



WALL DESIGNS AND DETAILS
FOR WASTE STORAGE

DRAWING NO. CW-10.10.10R

ISSUE DATE: 3/2004

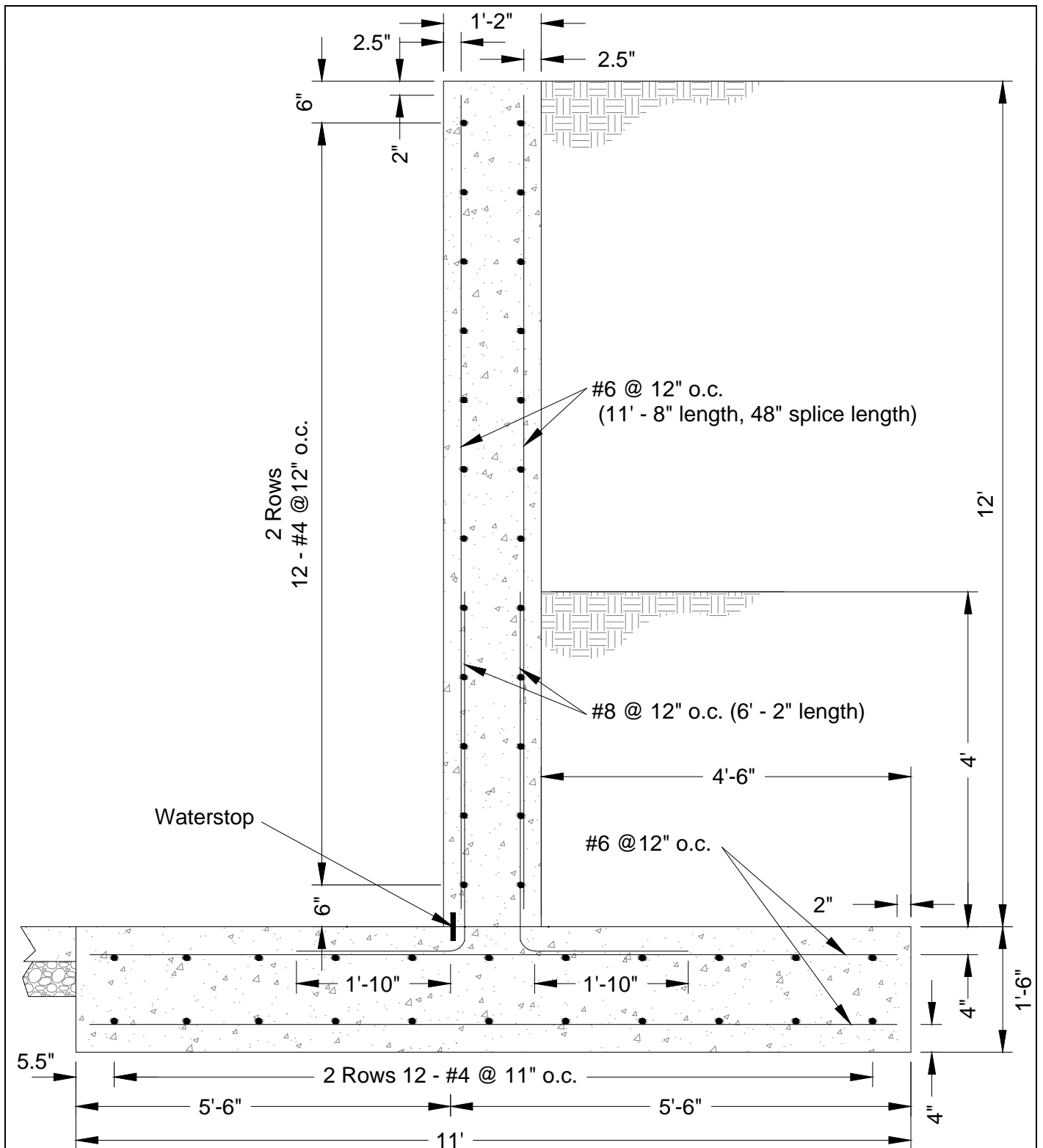

12' RETAINING WALL

Notes:

- | | |
|---------------------------------------|---|
| 1) 4000 psi concrete | 4) Minimum backfill 4' |
| 2) Grade 60 steel | 5) Concrete slab must be placed before wall is backfilled |
| 3) Maximum backfill top of wall (12') | 6) Maximum surcharge 100 PSF |

NTS

 <p>UNITED STATES DEPARTMENT OF AGRICULTURE</p> <p>NATURAL RESOURCES CONSERVATION SERVICE MARYLAND</p>	<p>WALL DESIGNS AND DETAILS FOR WASTE STORAGE</p>	DRAWING NO. CW-12.12.4
		ISSUE DATE: 3/2004

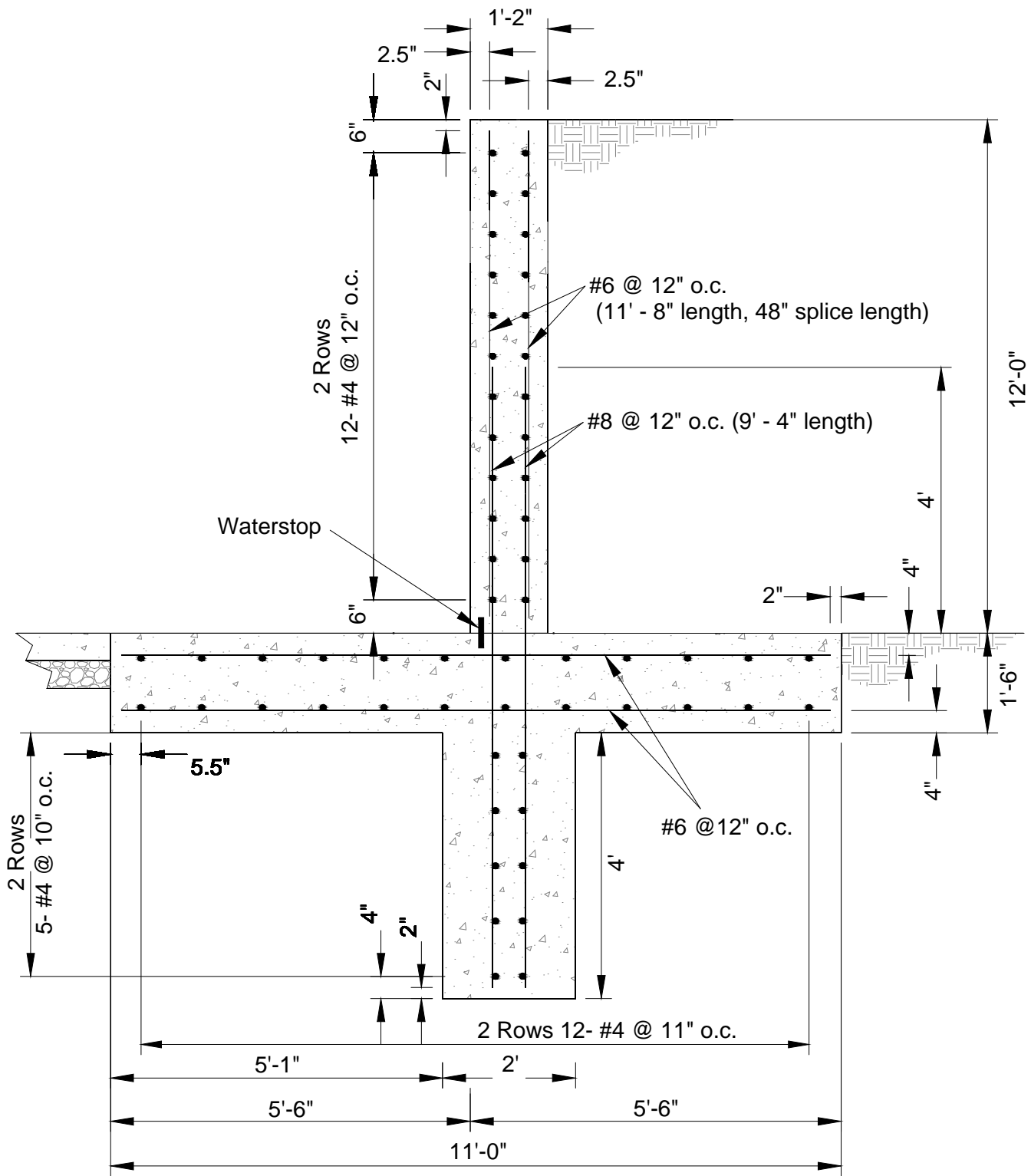

12' RETAINING WALL

Notes:

- | | |
|---------------------------------------|---|
| 1) 4000 psi concrete | 4) Minimum backfill top of floor |
| 2) Grade 60 steel | 5) Concrete slab must be placed before wall is backfilled |
| 3) Maximum backfill top of wall (12') | 6) Maximum surcharge 100 PSF |

NTS



NATURAL RESOURCES CONSERVATION SERVICE
MARYLAND

WALL DESIGNS AND DETAILS FOR WASTE STORAGE

DRAWING NO. CW-12.12.0

ISSUE DATE: 3/2004

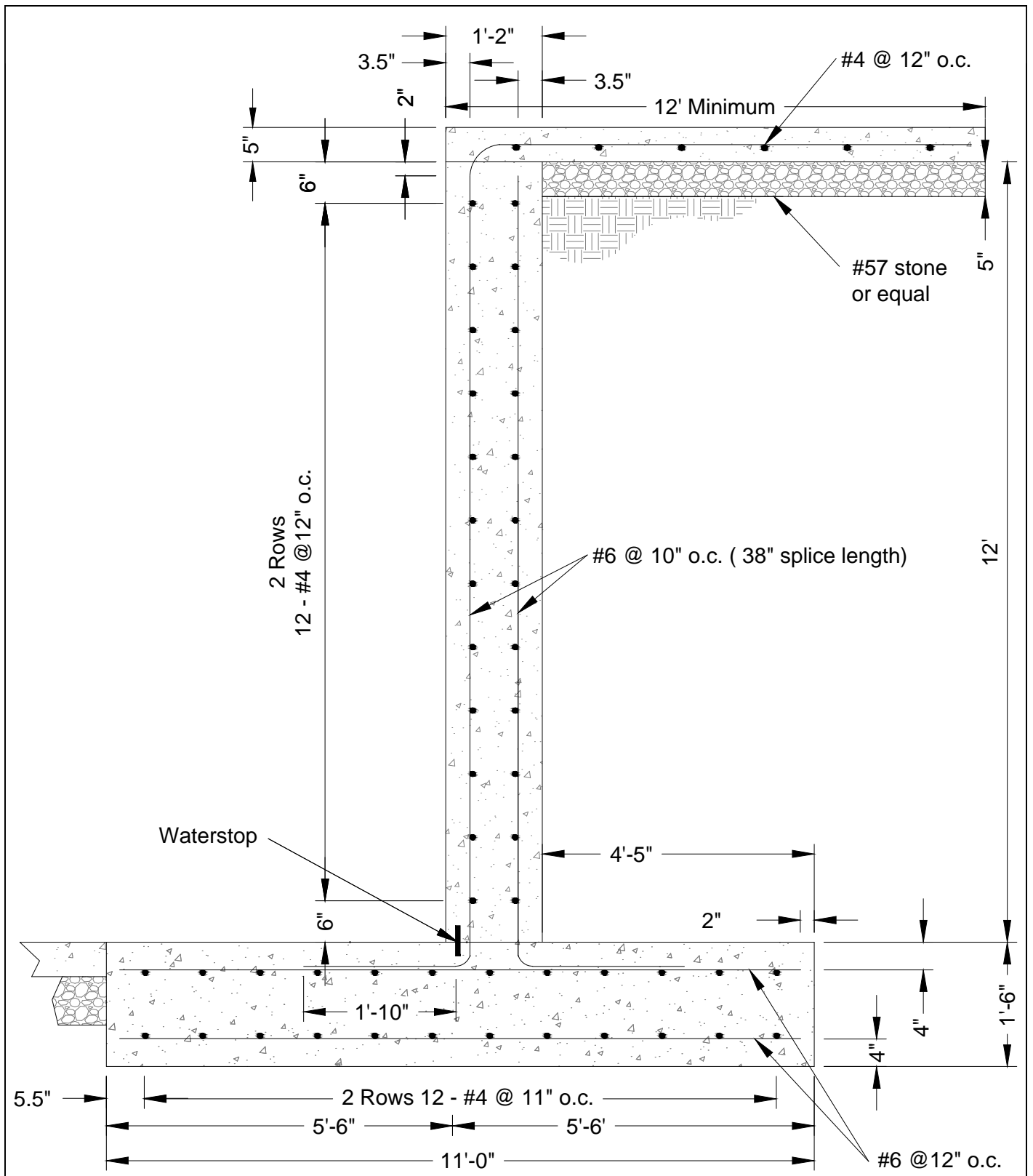

- 12' RETAINING WALL**
NTS
- Notes:
- 1) 4000 psi concrete
 - 2) Grade 60 steel
 - 3) Maximum backfill top of wall (12')
 - 4) Concrete slab must be placed before wall is backfilled
 - 5) Maximum surcharge 100 PSF